



NOTICE OF INCORPORATION

United States Legal Document

 All citizens and residents are hereby advised that this is a legally binding document duly incorporated by reference and that failure to comply with such requirements as hereby detailed within may subject you to criminal or civil penalties under the law. Ignorance of the law shall not excuse noncompliance and it is the responsibility of the citizens to inform themselves as to the laws that are enacted in the United States of America and in the states and cities contained therein. 

* *
*

ASME A17.7, Performance-Based Safety Code for Elevators and Escalators , 2007 Edition, as required by States and Municipalities, including Idaho, Iowa, Nevada, Ohio, et. alia.

ASME A17.7-2007/CSA B44.7-07

Performance-based safety code for elevators and escalators



The American Society of
Mechanical Engineers



CANADIAN STANDARDS
ASSOCIATION



Legal Notice for Harmonized Standard Jointly Developed by ASME and CSA

Intellectual property rights and ownership

As between American Society of Mechanical Engineers ("ASME") and Canadian Standards Association ("CSA") (collectively "ASME and CSA") and the users of this document (whether it be in printed or electronic form), ASME and CSA are the joint owners of all works contained herein that are protected by copyright, all trade-marks (except as otherwise noted to the contrary), and all inventions and trade secrets that may be contained in this document, whether or not such inventions and trade secrets are protected by patents and applications for patents. The unauthorized use, modification, copying, or disclosure of this document may violate laws that protect the intellectual property of ASME and CSA and may give rise to a right in ASME and CSA to seek legal redress for such use, modification, copying, or disclosure. ASME and CSA reserve all intellectual property rights in this document.

Disclaimer and exclusion of liability

This document is provided without any representations, warranties, or conditions of any kind, express or implied, including, without limitation, implied warranties or conditions concerning this document's fitness for a particular purpose or use, its merchantability, or its non-infringement of any third party's intellectual property rights. ASME and CSA do not warrant the accuracy, completeness, or currency of any of the information published in this document. ASME and CSA make no representations or warranties regarding this document's compliance with any applicable statute, rule, or regulation.

IN NO EVENT SHALL ASME AND CSA, THEIR RESPECTIVE VOLUNTEERS, MEMBERS, SUBSIDIARIES, OR AFFILIATED COMPANIES, OR THEIR EMPLOYEES, DIRECTORS, OR OFFICERS, BE LIABLE FOR ANY DIRECT, INDIRECT, OR INCIDENTAL DAMAGES, INJURY, LOSS, COSTS, OR EXPENSES, HOWSOEVER CAUSED, INCLUDING BUT NOT LIMITED TO SPECIAL OR CONSEQUENTIAL DAMAGES, LOST REVENUE, BUSINESS INTERRUPTION, LOST OR DAMAGED DATA, OR ANY OTHER COMMERCIAL OR ECONOMIC LOSS, WHETHER BASED IN CONTRACT, TORT (INCLUDING NEGLIGENCE), OR ANY OTHER THEORY OF LIABILITY, ARISING OUT OF OR RESULTING FROM ACCESS TO OR POSSESSION OR USE OF THIS DOCUMENT, EVEN IF ASME OR CSA HAVE BEEN ADVISED OF THE POSSIBILITY OF SUCH DAMAGES, INJURY, LOSS, COSTS, OR EXPENSES.

In publishing and making this document available, ASME and CSA are not undertaking to render professional or other services for or on behalf of any person or entity or to perform any duty owed by any person or entity to another person or entity. The information in this document is directed to those who have the appropriate degree of experience to use and apply its contents, and ASME and CSA accept no responsibility whatsoever arising in any way from any and all use of or reliance on the information contained in this document.

ASME and CSA have no power, nor do they undertake, to enforce compliance with the contents of the standards or other documents they jointly publish.

Authorized use of this document

This document is being provided by ASME and CSA for informational and non-commercial use only. The user of this document is authorized to do only the following:

If this document is in electronic form:

- load this document onto a computer for the sole purpose of reviewing it;
- search and browse this document; and
- print this document.

Limited copies of this document in print or paper form may be distributed only to persons who are authorized by ASME and CSA to have such copies, and only if this Legal Notice appears on each such copy.

In addition, users may not and may not permit others to

- alter this document in any way or remove this Legal Notice from the attached standard;
- sell this document without authorization from ASME and CSA; or
- make an electronic copy of this document.

If you do not agree with any of the terms and conditions contained in this Legal Notice, you may not load or use this document or make any copies of the contents hereof, and if you do make such copies, you are required to destroy them immediately. Use of this document constitutes your acceptance of the terms and conditions of this Legal Notice.



The American Society of
Mechanical Engineers



CANADIAN STANDARDS
ASSOCIATION

Page intentionally blank



CSA Standards Update Service

ASME A17.7-2007/CSA B44.7-07

March 2007

Title: *Performance-based safety code for elevators and escalators*

Pagination: **131 pages** (xvii preliminary and 114 text), each dated **March 2007**

Automatic notifications about any updates to this publication are available.

- To register for e-mail notifications, and/or to download any existing updates in PDF, enter the Online Store at **www.ShopCSA.ca** and click on **My Account** on the navigation bar.

The **List ID** for this document is **2018369**.

- To receive printed updates, please complete and return the attached card.

Name _____

Organization _____

Address _____

City _____

Province/State _____

Country _____ Postal/Zip Code _____

E-mail _____

I consent to CSA collecting and using the above information to send me updates relating to this publication.

Visit CSA's policy on privacy at www.csagroup.org/legal to find out how we protect your personal information.

ASME A17.7-2007/CSA B44.7-07

Affranchir
suffisamment

Place
Stamp Here

**ASSOCIATION CANADIENNE DE
NORMALISATION**
BUREAU CENTRAL DE L'INFORMATION
5060, SPECTRUM WAY, BUREAU 100
MISSISSAUGA ON L4W 5N6
CANADA

**CANADIAN STANDARDS
ASSOCIATION**
CONSOLIDATED MAILING LIST
5060 SPECTRUM WAY, SUITE 100
MISSISSAUGA ON L4W 5N6
CANADA

ASME/CSA Standard

ASME A17.7-2007

CSA B44.7-07

***Performance-based safety code for elevators
and escalators***



The American Society of
Mechanical Engineers[®]



**CANADIAN STANDARDS
ASSOCIATION**

[®]Registered trade-mark of Canadian Standards Association



Commitment for Amendments

This Standard is issued jointly by the American Society of Mechanical Engineers (ASME) and the Canadian Standards Association (CSA). Amendments to this Standard will be made only after processing according to the Standards writing procedures of both ASME and CSA.

The American Society of Mechanical Engineers (ASME)
Three Park Avenue
New York, NY 10016-5990
USA
www.asme.org

ISBN 0-7918-3099-3

© Copyright 2007

The 2007 edition of this Standard is being issued with an automatic addenda subscription service. The use of addenda allows revisions made in response to public review comments or committee actions to be published as necessary.

Published in March 2007 by Canadian Standards Association
A not-for-profit private sector organization
5060 Spectrum Way, Suite 100
Mississauga, Ontario, Canada
L4W 5N6

To purchase CSA Standards and related publications, visit CSA's Online Store at www.ShopCSA.ca or call toll-free 1-800-463-6727 or 416-747-4044.

ISBN 1-55436-165-6

© Canadian Standards Association — 2007

All rights reserved. No part of this publication may be reproduced in any form whatsoever without the prior permission of the publisher.



Contents

ASME A17 Elevator and Escalator Committee v

CSA B44 Technical Committee on the Elevator Safety Code vii

ASME A17.7/CSA B44.7 Committee on New Technology x

Foreword xii

ASME Preface xiii

CSA Preface xv

Form and arrangement xvi

1 GENERAL 1

1.1 SCOPE 1

1.2 PURPOSE 2

1.3 DEFINITIONS 2

2 SAFETY REQUIREMENTS 5

2.1 PROCESSES FOR ESTABLISHING SAFETY 5

2.2 OPTIONS FOR ESTABLISHING SAFETY 6

2.3 SAFETY ASSESSMENT SUBJECT 6

2.4 ASSURING SAFETY BY IMPLEMENTING GESRs 7

2.5 SORTING OF APPLICABLE GESRs FOR APPROACH 1 8

2.6 IMPLEMENTATION OF GESRs 9

2.7 RISK ASSESSMENT PROCESS 9

2.8 PROTECTIVE MEASURES AND SAFETY PRINCIPLES 11

2.9 APPLICATION OF SPs 12

2.10 CODE COMPLIANCE DOCUMENTATION 13

2.11 CODE DATA PLATE 13

2.12 ADDITIONAL REQUIREMENTS 13

3 GLOBAL ESSENTIAL SAFETY REQUIREMENTS (GESRs) FOR ELEVATORS 15

3.1 COMMON GESRs RELATED TO PERSONS AT DIFFERENT LOCATIONS 15

3.2 GESRs RELATED TO PERSONS ADJACENT TO THE ELEVATOR — FALLING INTO HOISTWAY 17

3.3 GESRs RELATED TO PERSONS AT THE ELEVATOR ENTRANCE 18

3.4 GESRs RELATED TO PERSONS IN THE LCU (CAR) 19

3.5 GESRs RELATED TO PERSONS IN WORKING AREAS 21

4 SAFETY PARAMETERS 23

5 REFERENCE CODES AND STANDARDS 25

5.1 REFERENCE DOCUMENTS 25

5.2 PROCUREMENT INFORMATION 29

MANDATORY APPENDIX I — CERTIFICATION OF CONFORMANCE OF ELEVATOR SYSTEMS,
SUB-SYSTEMS, COMPONENTS, OR FUNCTIONS 31



NONMANDATORY APPENDICES

- A** — BACKGROUND TO GESRs 35
B — SAFETY PARAMETERS 53
C — RISK ASSESSMENT METHODOLOGIES 78
D — QUICK REFERENCES 83
E — EXAMPLE OF USE OF THIS CODE 87
F — ASME A17.7/CSA B44.7 Process 114

Tables

- A-1** — Examples of risk scenarios related to GESRs 36
A-3 — Cross-Referencing of GESRs in Part 3 and Elevator Sub-Systems 42
A-4 — Cross-Referencing of GESRs in Part 3 and Elevator Sub-Systems 48
B-1 — SPs for Each GESR 54
B-2 — Summary of Anthropometric Data 76
C-1 — Risk Assessment Template 79
C-2.1 — Levels of Severity 80
C-2.2 — Levels of Probabilities 80
C-3.1 — Risk Estimation and Evaluation 87
C-3.2 — Risk Evaluation 87
C-4 — Guide for Team Moderator — Role, Skills, Duties, and Responsibilities 82
D-1 — Examples of Hazards 83
D-2 — Examples of Hazardous Situations 84
D-3 — Examples of Causes (Component of Harmful Event) 85
D-4 — Examples of Possible Effects 86
E-2.3 — List of GESRs to be Verified for Conformance 89
E-2.4 — Risk Assessment per Nonmandatory Appendix C 96

Figures

- E-1** — Determination of the Subject of the Assessment 109
E-2a — Elaboration of the Design Concept 110
E-2b — View of Ground Guard and Raised LCU 111
E-3 — Elaboration of Design Concept LCU – Landing Bridge 112
E-4 — Elaboration of the Design Concept 113
F-1 — ASME A17.7/CSA B44.7 Process 114



ASME A17 Elevator and Escalator Committee

J. W. Coaker, *Chair*
H. E. Peelle III, *Vice Chair*
N. B. Martin, *Vice Chair*
G. A. Burdeshaw, *Secretary*
E. V. Baker, NEIEP
R. E. Baxter, Richard E. Baxter and Associates, LLC
L. Bialy, Otis Elevator Co.
N. Marchitto, *Alternate*, Otis Elevator Co.
J. R. Brooks, North Carolina Department of Labor
W. C. Burklund, Kone, Inc.
J. W. Coaker, Coaker & Co., PC
E. A. Donoghue, Edward A. Donoghue Associates, Inc.
R. E. Droste, Consultant
J. A. Filippone, Port Authority of New York and New Jersey
J. H. Humphrey, *Alternate*, Port Authority of New York and New Jersey
C. C. Fox, Rainbow Security Control Ltd.
G. W. Gibson, George W. Gibson and Associates, Inc.
R. A. Gregory, Vertex Corp.
A. P. Juhasz, Kone, Inc.
L. C. Kanicki, Elevator Subcode Official Township of Burlington NJ
G. A. Kappenhagen, Schindler Elevator Corp.
J. W. Koshak, Thyssen Krupp Elevator Co.
H. Simpkins, *Alternate*, Thyssen Krupp Elevator Co.
K. S. Lloyd, Abell Elevator International
S. K. Lloyd, *Alternate*, Abell Elevator International
N. B. Martin, Chief Elevator Insp. State of Ohio
Z. R. McCain, Jr., McCain Engineering Associates, Inc.
M. V. Farinola, *Alternate*, MV Farinola, Inc.
D. A. McColl, Otis Canada, Inc.
H. E. Peelle III, The Peelle Co., Ltd.
S. P. Reynolds, *Alternate*, The Peelle Co., Ltd.
R. L. Phillips, Georgia Department of Labor
A. Rehman, Schindler Elevator Corp.
V. P. Robibero, Schindler Elevator Corp.
C. W. Rogler, State of Michigan
R. L. Seymour, Robert L. Seymour and Associates, Inc.
R. S. Seymour, *Alternate*, Robert L. Seymour and Associates, Inc.
D. L. Steel, David L. Steel Escalators
D. L. Turner, Davis L. Turner and Associates
R. S. Caporale, *Alternate*, Elevator World, Inc.
A. H. Verschell, Consulting Engineer



C. E. Vlahovic, TSSA
R. Hadaller, *Alternate*, TSSA
D. M. Winkle, IUEC Local #14
D. A. Witham, GAL Manufacturing

Honorary Members

L. J. Blaiotta
W. E. Chamberlain
B. J. Fanguy
W. J. Figiel
H. E. Godwin, Jr.
C. E. Hempel
C. L. Kort
A. A. Mascone
J. McAulay, Jr.
E. M. Philpot
R. L. Rogers
R. W. Young
L. E. White



CSA B44 Technical Committee on the Elevator Safety Code

R. Hadaller	Technical Standards & Safety Authority, Toronto, Ontario, Canada	<i>Chair</i>
D. McColl	Otis Canada, Inc., Mississauga, Ontario, Canada	<i>Vice-Chair</i>
T. Baik	Toronto Transit Commission, Toronto, Ontario, Canada	
G. Befekadu	Oil Lift Systems Inc., Ayr, Ontario, Canada	<i>Associate</i>
L. Bialy	Otis Elevator Company, Farmington, Connecticut, USA	<i>Associate</i>
B. Blackaby	Otis Elevator Company, Farmington, Connecticut, USA	<i>Associate</i>
S. Bornstein	KONE Inc., Toronto, Ontario, Canada	
M. Brierley	Coldwater, Ontario, Canada	<i>Associate</i>
A. Brown	KONE Inc., Toronto, Ontario, Canada	<i>Associate</i>
A. Byram	New Brunswick Department of Public Safety, Saint John, New Brunswick, Canada	
R. Cavan	Human Resources and Social Development Canada, Ottawa, Ontario, Canada	
D. Cook	Coquitlam, British Columbia, Canada	
E. Donoghue	Edward A. Donoghue Associates Incorporated, Salem, New York, USA	<i>Associate</i>
R. Droste	Avon, Connecticut, USA	<i>Associate</i>
D. Eastman	Government of Newfoundland and Labrador, St. John's, Newfoundland, Canada	
G. Gibson	George W. Gibson & Associates Inc., Sedona, Arizona, USA	<i>Associate</i>
P. Girouard	Plafolift Inc., Warwick, Québec, Canada	<i>Associate</i>
A. Griffin	Alberta Municipal Affairs, Edmonton, Alberta, Canada	



A. Hopkirk	Canadian Elevator Contractors Association, Scarborough, Ontario, Canada	
U. Huskic	Fujitec Canada Inc., Richmond Hill, Ontario, Canada	
L. Janssens	Saskatchewan Corrections and Public Safety, Saskatoon, Saskatchewan, Canada	
I. Jay	British Columbia Safety Authority (BCSA), New Westminster, British Columbia, Canada	
K. Jenkins	KJA Consultants Inc., Montréal, Québec, Canada	
G. Kappenhagen	Schindler Elevator Corporation, Morristown, New Jersey, USA	<i>Associate</i>
F. Kassem	CNIM Canada Inc., Montréal, Québec, Canada	
I. Kennedy	Brighton, Ontario, Canada	
R. Kennedy	Nova Scotia Department of Environment and Labour, Halifax, Nova Scotia, Canada	
J. Koshak	ThyssenKrupp Elevator, Collierville, Tennessee, USA	<i>Associate</i>
M. Liberatore	Halifax, Nova Scotia, Canada	<i>Associate</i>
E. MacArthur	Prince Edward Island Department of Community and Cultural Affairs, Charlottetown, Prince Edward Island, Canada	
A. Marchant	Alimak Hek, Inc., Bridgeport, Connecticut, USA	
R. Marion	Government of the Northwest Territories, Yellowknife, Northwest Territories, Canada	
R. Marsiglio	H.H. Angus & Associates Ltd., Don Mills, Ontario, Canada	
L. Martineau	STM (Montréal Transport Society), Montréal, Québec, Canada	
A. McGregor	Rooney, Irving & Associates Ltd., Ottawa, Ontario, Canada	
B. McIntyre	IUEC Local No. 50, Scarborough, Ontario, Canada	
I. Mercer	Government of Newfoundland and Labrador, St. John's, Newfoundland, Canada	<i>Associate</i>
S. Mercier	Régie du bâtiment du Québec, Montréal, Québec, Canada	



M. Pedram	ThyssenKrupp Northern Elevator Corp., Scarborough, Ontario, Canada	
H. Peelle	The Peelle Company Limited, Brampton, Ontario, Canada	
A. Rehman	Schindler Elevator Corporation, Scarborough, Ontario, Canada	
A. Reistetter	National Elevator & Escalator Association, Mississauga, Ontario, Canada	<i>Associate</i>
T. Rieger	Manitoba Department of Labour and Immigration, Winnipeg, Manitoba, Canada	
J. Rooney	Priestman, Neilson & Associates Ltd., Kanata, Ontario, Canada	
R. Scharfe	Public Works and Government Services Canada, Ottawa, Ontario, Canada	
E. Sopeju	Underwriters' Laboratories of Canada, Scarborough, Ontario, Canada	<i>Associate</i>
B. Virk	Unitech Elevator Company, Pickering, Ontario, Canada	
D. Walton	Eastern Elevator Inc., Bowmanville, Ontario, Canada	<i>Associate</i>
D. Warne	Alberta Elevating Devices and Amusement Rides Safety Association, Calgary, Alberta, Canada	<i>Associate</i>
P. Yau	Public Works and Government Services Canada, Toronto, Ontario, Canada	
E. Zebedee	Government of Nunavut Community and Government Services, Iqaluit, Nunavut, Canada	<i>Associate</i>
T. Tulshi	Canadian Standards Association, Mississauga, Ontario, Canada	<i>Project Manager</i>



ASME A17.7/CSA B44.7 Committee on New Technology

J. Coaker	Coaker & Co Pc, Fairfax Station, Virginia, USA	<i>Chair</i>
G. Burdeshaw	American Society of Mechanical Engineers, New York, New York, USA	<i>Secretary</i>
R. Baxter	Richard E. Baxter & Associates, Llc, Allen, Texas, USA	<i>Alternate</i>
M. Bayyari	Fujitec America, Inc., Lebanon, Ohio, USA	
L. Bialy	Otis Elevator Company, Farmington, Connecticut, USA	
A. Brown	KONE Inc., Toronto, Ontario, Canada	<i>Corresponding Member</i>
A. Byram	New Brunswick Department of Public Safety, Saint John, New Brunswick, Canada	
R. Caporale	Elevator World Inc., Mobile, Alabama, USA	
L. Capuano	Elevator Engineering Services, Westfield, New Jersey, USA	
M. Chan	Technical Standards & Safety Authority, Toronto, Ontario, Canada	<i>Alternate</i>
E. Donoghue	Edward A. Donoghue Associates Incorporated, Salem, New York, USA	
R. Droste	Avon, Connecticut, USA	
G. Gibson	George W. Gibson & Associates Inc., Sedona, Arizona, USA	
A. Griffin	Alberta Municipal Affairs, Edmonton, Alberta, Canada	
I. Jay	British Columbia Safety Authority (BCSA), New Westminster, British Columbia, Canada	<i>Corresponding Member</i>
A. Juhasz	KONE Inc., Moline, Illinois, USA	
L. Kanicki	Township of Burlington, Lamberton, New Jersey, USA	
R. Kennedy	Nova Scotia Department of Environment and Labour, Halifax, Nova Scotia, Canada	



J. Koshak	ThyssenKrupp Elevator, Collierville, Tennessee, USA	
G. Kosinski	Elevator Industry Work Preservation Fund, San Antonio, Texas, USA	
R. Laney	Draka Elevator Products, Rocky Mount, North Carolina, USA	
K. Lloyd Jr.	Abell Elevator International, Louisville, Kentucky, USA	<i>Corresponding Member</i>
D. McColl	Otis Canada, Inc., Mississauga, Ontario, Canada	
M. Mihai	Technical Standards & Safety Authority, Toronto, Ontario, Canada	
M. Pedram	ThyssenKrupp Northern Elevator Corp., Scarborough, Ontario, Canada	
V. Robibero	Schindler Elevator Corp., Morristown, New Jersey, USA	
D. Stanlaske	Naesa International, Tumwater, Washington, USA	
T. Tulshi	Canadian Standards Association, Mississauga, Ontario, Canada	
D. Turner	Davis L. Turner & Assoc. Llc, Mission Viejo, California, USA	<i>Corresponding Member</i>



Foreword

Present ASME A17.1/CSA B44 Code requirements provide a framework for standards of safety for current products whose technologies have become state-of-the-art and commonplace. The ASME A17 and CSA B44 Committees have demonstrated responsiveness to prepare new requirements to cover newly introduced designs and technologies throughout their long histories, which span over 80 years.

The ASME A17 and CSA B44 Code Committees will continue their longstanding policies of revising Codes to keep them abreast of developments in the industry. The ASME A17 and CSA B44 Committees have responded to new developments throughout their histories, as evidenced by the inclusion of requirements to recognize technological advances (such as increased car speeds, solid state electronic devices, observation elevators, installation of counterweights in separate hoistways, material lifts and dumbwaiters with automatic transfer devices, special purpose personnel elevators, inclined elevators, elevators used for construction, limited-use/limited-application elevators, and shipboard elevators).

In a progressive elevator industry, designs and products emerge that are not specifically covered in the ASME A17.1/CSA B44 Code. Since Code requirements cannot anticipate future development and innovation in the elevator industry, they are written to reflect state-of-the-art technologies following introduction. Accordingly, products will be introduced prior to requirements being adopted into the ASME A17.1/CSA B44 Code.

With new materials and processes in mechanical, structural, electronic, and optics areas, in addition to analytical capabilities now available, the need for flexibility to introduce products resulting from maturing technical developments is heightened. The ASME A17.1 and CSA B44 Code Committees realized long ago that the time gap between the introduction of new technologies and introduction of relevant specific requirements in the Codes could hinder progress. Therefore, they introduced long-standing provisions, in Section 1.2, that suggest that Authorities Having Jurisdiction or Regulatory Authorities, hereafter referred to as AHJ, should recognize new systems, methods, or devices provided that they assure safety equivalent to that required by the Codes. However, the lack of a structured method for assessment of equivalency has proven to be a problem in the practical implementation of Section 1.2 provisions.

This new performance-based Code, ASME A17.7/CSA B44.7, provides an objective and structured method for establishing design and product safety. It is in the public interest that safe designs and products be introduced into the marketplace. Safeguards must be provided and documentation must be presented to show that designs and products are equivalent or superior in quality, strength, stability, fire resistance, effectiveness, durability, and safety to that intended by the ASME A17.1/CSA B44 Code. This structured method also provides a consistent means of demonstrating safety of designs and products, which will be helpful to AHJ.



ASME Preface

General

This performance-based Code is one of numerous codes and standards developed and published by the American Society of Mechanical Engineers (ASME) under the general auspices of the American National Standards Institute, Inc. (ANSI).

The Code is intended to serve as the basis for design, construction, installation, operation, testing, inspection, maintenance, alteration, and repair of elevators, dumbwaiters, escalators, moving walks, and material lifts.

Safety codes and standards are intended to enhance public health and safety. Revisions result from committee consideration of factors such as technological advances, new data, and changing environmental and industry needs. Revisions do not imply that previous editions were inadequate.

The following conditions are not addressed in this Code:

- (a) assignment of the responsibility for compliance to any particular party;
- (b) frequency of periodic inspections and tests; and
- (c) assignment of responsibility for persons authorized to make and witness inspections and tests.

Correspondence with ASME A17 Committee

ASME codes and standards are developed and maintained with the intent to represent the consensus of concerned interests. As such, users of this and other ASME A17 codes and standards may interact with the committee by requesting interpretations, proposing revisions, and attending committee meetings.

Correspondence should be addressed to:

Secretary, A17 Standards Committee
The American Society of Mechanical Engineers
Three Park Avenue
New York, NY 10016 USA
E-mail: infocentral@asme.org

All correspondence to the Committee must include the individual's name and post office address in case the Committee needs to request further information.

Proposing revisions

Revisions are made periodically to the Code to incorporate changes that appear necessary or desirable, as demonstrated by the experience gained from the application of the procedures, and in order to conform to developments in the elevator industry. Approved revisions will be published periodically.

The ASME A17 Committee welcomes proposals for revisions to this Code. Such proposals should be as specific as possible, citing the section number(s), the proposed wording, and a detailed description of the reasons for the proposal, including any pertinent documentation.

Requesting interpretations

On request, the ASME A17 Committee will render an interpretation of any requirement of the Code. Interpretations can be rendered only in response to a written request sent to the Secretary of the Standards Committee.

The request for interpretation should be clear and unambiguous. It is further recommended that the inquirer submit the request using the following format:



- Subject:* Cite the applicable section number(s) and give a concise description.
- Edition:* Cite the applicable edition and supplement of the Code for which the interpretation is being requested.
- Question:* Phrase the question as a request for an interpretation of a specific requirement suitable for general understanding and use, not as a request for approval of a proprietary design or situation. The question shall be phrased, where possible, to permit a specific “yes” or “no” answer. The inquirer may also include any plans or drawings that are necessary to explain the question; however, they should not contain proprietary names or information.

Requests that are not in this format will be rewritten in this format by the Committee prior to being answered, which may inadvertently change the intent of the original request.

ASME procedures provide for reconsideration of any interpretation if additional information that might affect an interpretation becomes available. Further, persons aggrieved by an interpretation may appeal to the appropriate ASME committee or subcommittee. ASME does not “approve,” “certify,” “rate,” or “endorse” any item, construction, proprietary device, or activity.

Attending Committee meetings

The ASME A17 Standards Committee and the various Working Committees regularly hold meetings, all of which are open to the public. Persons wishing to attend any meeting should contact the Secretary of the Standards Committee.



CSA Preface

This is the first edition of ASME A17.7/CSA B44.7, *Performance-based safety code for elevators and escalators*. This is a fully harmonized binational Code.

This Code is considered suitable for use for conformity assessment within the stated scope of the Code.

This Code was prepared for use in Canada by the CSA Technical Committee on the Elevator Safety Code under the jurisdiction of the CSA Strategic Steering Committee on Public Safety. It has been formally approved by the CSA Technical Committee.

March 2007

Notes:

- (1) Use of the singular does not exclude the plural (and vice versa) when the sense allows.
- (2) Although the intended primary application of this Code is stated in its Scope, it is important to note that it remains the responsibility of the users of the Code to judge its suitability for their particular purpose.
- (3) This publication was developed by consensus, which is defined by CSA Policy governing standardization — Code of good practice for standardization as "substantial agreement. Consensus implies much more than a simple majority, but not necessarily unanimity". It is consistent with this definition that a member may be included in the Technical Committee list and yet not be in full agreement with all clauses of this publication.
- (4) CSA Codes and Standards are subject to periodic review, and suggestions for their improvement will be referred to the appropriate committee.
- (5) All enquiries regarding this Code, including requests for interpretation, should be addressed to Canadian Standards Association, 5060 Spectrum Way, Suite 100, Mississauga, Ontario, Canada L4W 5N6.
Requests for interpretation should
 - (a) define the problem, making reference to the specific clause, and, where appropriate, include an illustrative sketch;
 - (b) provide an explanation of circumstances surrounding the actual field condition; and
 - (c) be phrased where possible to permit a specific "yes" or "no" answer.Committee interpretations are processed in accordance with the CSA Directives and guidelines governing standardization and are published in CSA's periodical Info Update, which is available on the CSA Web site at www.csa.ca.
- (6) Attention is drawn to the possibility that some of the elements of this Standard may be the subject of patent rights. CSA is not to be held responsible for identifying any or all such patent rights. Users of this Standard are expressly advised that determination of the validity of any such patent rights is entirely their own responsibility.



Form and arrangement

General

This Code consists of parts and sections, each covering a specific subject so as to facilitate reference to the requirements.

The foreword, prefaces, notes, and nonmandatory appendices included in this Code and any interpretations provided subsequently are not part of this Code. They are advisory in nature and are intended for clarification only.

Abbreviation	Unit	Abbreviation	Unit
h	hour	m/s ²	meter per second per second
J	Joule	mm	millimeter
kg	kilogram	mm ²	square millimeter
kg/m ²	kilogram per square meter	mm ³	cubic millimeter
kPa	kilopascal	MPa	megapascal
lx	lux	N	Newton
m	meter	s	second
m ²	square meter	W	Watt
m ³	cubic meter		
m/s	meter per second		

Acronyms used in this Code

AECO	Accredited Elevator/Escalator Certification Organization
AHJ	Authority Having Jurisdiction (Regulatory Authority)
ANSI	American National Standards Institute
ASME	American Society of Mechanical Engineers
CCD	Code Compliance Document
CSA	Canadian Standards Association
EN	European Norms
EPD	Electrical Protective Device
FMEA	Failure Mode and Effects Analysis
FOS	Factor of Safety
FTA	Fault Tree Analysis
GESR	Global Essential Safety Requirement
ISO	International Organization for Standardization
KE	Kinetic Energy
LCU	Load-Carrying Unit (Car)
MCP	Maintenance Control Program
MOSAR	Method Organized for Systematic Analysis of Risk
PES	Programmable Electronic System
PHA	Preliminary Hazard Analysis
RA	Risk Assessment



SCC Standards Council of Canada
SIL Safety Integrity Level
SP Safety Parameter
S/P Severity/Probability
TC Technical Committee
UTS Ultimate Tensile Strength

Note (Acronyms used in this Code): See also Part 5 for acronyms used for referenced standards.

SI (metric) units

This Code is written in SI (metric) units. Information on SI usage and conversion to imperial units is contained in IEEE/ASTM SI 10-1997, *Standard for the Use of the International System of Units (SI): The Modern Metric System*, ASME Guide SI-1, *Orientation and Guide for Use of SI (Metric) Units*, and CAN/CSA-Z234.1, *Canadian Metric Practice Guide*.



Page intentionally blank



PART 1 GENERAL

SECTION 1.1 SCOPE

1.1.1 Equipment Covered by this Code

This Code covers the design, construction, operation, inspection, testing, maintenance, alteration, and repair of the following equipment and its associated parts, rooms, spaces, and hoistways, where located in or adjacent to a building or structure:

- (a) hoisting and lowering mechanisms, equipped with a car, that move between two or more landings. This equipment includes, but is not limited to, elevators (see 1.3);
- (b) power-driven stairways and walkways for carrying persons between landings. This equipment includes, but is not limited to, escalators and moving walks (see 1.3); and
- (c) hoisting and lowering mechanisms, equipped with a car, that serve two or more landings and are restricted to the carrying of material by their limited size or limited access to the car. This equipment includes, but is not limited to, dumbwaiters and material lifts (see 1.3).

NOTE 1.1.1(b) and (c): Only elevators are covered in this edition. Other equipment is to comply with 1.2(a). Provision is made for other equipment to be covered in future editions.

1.1.2 Equipment Not Covered by this Code

Equipment not covered by this Code includes, but is not limited to, the following:

- (a) personnel hoists within the scope of ANSI A10.4 and CSA Z185;
- (b) material hoists within the scope of ANSI A10.5 and CSA Z256;
- (c) platform lifts and stairway chairlifts within the scope of ASME A18.1, CSA B355, and CSA B613;
- (d) manlifts within the scope of ASME A90.1 and CSA B311;
- (e) mobile scaffolds, towers, and platforms within the scope of ANSI A92 and the CSA B354 series of standards;
- (f) powered platform and equipment for exterior and interior building maintenance within the scope of ASME A120.1 and CSA Z271;
- (g) conveyors and related equipment within the scope of ASME B20.1;
- (h) cranes, derricks, hoists, hooks, jacks, and slings within the scope of ASME B30, CSA Z150, CSA B167, and CSA Z248;
- (i) industrial trucks within the scope of ASME B56 and CSA B335;
- (j) portable equipment, except for portable escalators;
- (k) tiering or piling machines used to move material to and from storage located and operating entirely within one story;
- (l) equipment for feeding or positioning material at machine tools, printing presses, etc.;
- (m) skip or furnace hoists;
- (n) wharf ramps;
- (o) amusement devices;
- (p) stage and orchestra lifts;
- (q) lift bridges;
- (r) railroad car lifts and dumpers;
- (s) mechanized parking garage equipment;
- (t) line jacks, false cars, shafters, moving platforms, and similar equipment used for installing an elevator;
- (u) platform elevators installed in a ship or offshore drilling rig and used for the purpose of loading and unloading cargo, equipment, and personnel;
- (v) dock levelers (freight platform lifts) having a travel of 500 mm (20 in.) or less;



- (w) in Canadian jurisdictions, devices having a travel of 2 000 mm (79 in.) or less and used only for the transfer of materials or equipment.

1.1.3 Effective Date

The requirements of this edition and subsequent addenda to the Code are effective as of the date noted on the copyright page of this document. The AHJ will establish the effective date for its local regulations.

SECTION 1.2 PURPOSE

The purpose of this Code is to provide a method for establishing the safety of life and limb, and to promote the public welfare. Compliance with this Code shall be achieved by

- (a) conformance with the requirements in ASME A17.1/CSA B44;
- (b) conformance with some of the requirements in ASME A17.1/CSA B44 and for elevator systems, sub-systems, components, or functions that do not conform with certain requirements in ASME A17.1/CSA B44, conformance with the applicable requirements in this Code; or
- (c) conformance with the requirements in this Code.

NOTE (1.2): Compliance with ASME A17.7/CSA B44.7 is not an alternative to compliance with requirements in other Codes and Standards not within the purview of ASME A17.1/CSA B44, such as NFPA 70, CSA C22.1, building codes, ICC/ANSI A117.1, etc.

SECTION 1.3 DEFINITIONS

Section 1.3 defines various terms used in this Code. The terms defined in ASME A17.1/CSA B44, Section 1.3, also apply, except as modified by the following:

Accredited Elevator/Escalator Certification Organization (AECO): An ANSI, ASME, or SCC accredited, independent organization concerned with product safety evaluation, which awards certificates of conformance with ASME A17.7.1/CSA B44.7.1.

NOTE [Accredited Elevator/Escalator Certification Organization (AECO)]: For the purpose of this definition, "accredited" means that an organization has been evaluated and approved by ANSI, ASME, or SCC to operate a certification program, and is designated as such by ANSI, ASME, or SCC.

applicant: the manufacturer or installer that submits the component(s) or the elevator system(s) for certification to an AECO for the purpose of obtaining a "Certificate of Conformance to ASME A17.7.1/CSA B44.7.1".

cause: circumstance, condition, event, or action that, in a hazardous situation, contributes to the production of an effect. ¹

certification: see ISO/IEC 17000.

effect: result of a cause in the presence of a hazardous situation. ¹

electromagnetic compatibility: degree of immunity to incident electromagnetic radiation and level of emitted electromagnetic radiation of electrical apparatus. ²

fully loaded LCU (car): LCU (car) loaded with its rated load. ²

global essential safety requirement (GESR): globally agreed-upon essential safety requirement. ²

harm: physical injury or damage to the health of people, or damage to property or the environment. ³



harmful event: occurrence in which a hazardous situation results in harm. ³

NOTE (*harmful event*): In this Code, the combination of “cause” and “effect, including harm” forms a “harmful event”.

hazard: potential source of harm. ³

NOTE (*hazard*): The term “hazard” can be qualified in order to define its origin or the nature of the expected harm (such as electric shock hazard, crushing hazard, cutting hazard, toxic hazard, fire hazard, and/or drowning hazard).

hazardous situation: circumstance in which people, property, or the environment are exposed to one or more hazards. ³

installer of an elevator: the legal entity that takes responsibility for the installation and placing of an elevator system, sub-system, component, or function into service.

life cycle: period of usage of a component or an elevator system. ¹

load-carrying unit (LCU) (car): part of an elevator designed to carry persons and/or other goods for the purpose of transportation. ²

manufacturer: the legal entity that takes responsibility for design and manufacture of an elevator system, sub-system, component, or function.

model elevator: a representative elevator whose technical description shows the way in which the GESRs will be met for a series-produced group of elevators having a defined range of application and operation.

non-user: person in the vicinity of the elevator but not intending to access or use the elevator. ²

overload, overloaded: load in the LCU (car) exceeds the elevator rated load. ²

platform: part of LCU (car) that accommodates persons and load for the purpose of transportation. ²

NOTE (*platform*): See also ASME A17.1/CSA B44, Section 1.3, definition of “car platform”.

protective measure: means used to reduce risk. ³

NOTE (*protective measure*): Protective measures include risk reduction by inherently safe design, removal of hazard, protective devices, personal protective equipment, information for use and installation, and training.

reasonably foreseeable misuse: use of a product, process, or service in a way not intended by the manufacturer, but which may result from readily predictable human behavior. ³

relative movement: situation where an elevator component moves in the vicinity of other elevator components that are stationary or move at different speeds or in different directions; also a situation where an elevator component moves in the vicinity of a structure where persons may be present.

EXAMPLE (*relative movement*): Building floor surrounding the elevator hoistway.

residual risk: risk remaining after protective measures have been taken. ³

risk: combination of the probability of occurrence of harm and the severity of that harm. ³

risk analysis: systematic use of available information to identify hazards and to estimate the risk. ³

risk assessment: overall process comprising a risk analysis and a risk evaluation. ³

risk evaluation: consideration of the risk analysis results to determine if risk reduction is required. ¹

safety parameter (SP): a quantitative unit, the value of which provides a level of safety consistent with that provided by relevant codes and standards in current use in the elevator industry and good engineering practices.



safety requirement (SR): requirement intended to eliminate or sufficiently mitigate the risk of harm to users, non-users, and elevator personnel using or associated with elevators and escalators.

scenario: sequence of a hazardous situation, cause, and effect. ¹

severity: level of potential harm. ¹

travel path: path and related space within which an LCU (car) travels between the elevator terminal landings. ²

NOTE (travel path): For “space” above and below the terminal landings, see definition of “hoistway” in ASME A17.1/CSA B44.

uncontrolled movement: situation where an LCU (car) moves when, according to design of the elevator, it was to remain stopped, or where an LCU (car) travels at a speed that is out of control of the elevator means designed and intended to control the LCU (car) speed during the elevator operation. ²

EXAMPLES (uncontrolled movement):

(1) An LCU (car) starts to move away from a landing while the users are entering or leaving the LCU (car), due to failure of, or breakdown in, elevator components, such as speed control, driving machine, or brake system.

(2) The LCU (car) speed exceeds its designed speed or does not decelerate or stop as intended, due to failure of, or breakdown in, elevator components, such as speed control, driving machine, or brake system.

user: person using the elevator for the purpose of normal transportation, without any help or supervision, including a person carrying freight and a person using a specially dedicated operating system to transport freight or loads. ²

NOTE (user): An example of the use of a specially dedicated operating system is “hospital service” for transport of hospital patients, whereby the operation of the elevator is solely under control of the patient’s attendant.

working area or space: area or space defined for use by elevator personnel to perform maintenance, inspection, or testing of the elevator. ²

NOTES (1.3):

¹ ISO 14798 – Risk assessment and risk reduction methodology.

² ISO/TS 22559-1 – Safety requirements for lifts (elevators) – Part 1 – Global essential safety requirements (GESRs) for lifts (elevators).

³ ISO/IEC Guide 51 – Safety aspects – Guidelines for their inclusion in standards.



PART 2 SAFETY REQUIREMENTS

SECTION 2.1 PROCESSES FOR ESTABLISHING SAFETY

2.1.1 ASME A17.1/CSA B44 Process

2.1.1.1

To ensure that an elevator is safe for public utilization, protective measures shall be implemented in the course of design, production, installation, inspection, testing, operation, maintenance, alteration, and repair. Effectiveness of protective measures shall be preserved through the life cycle of the elevator. Safety is conventionally achieved by meeting applicable requirements of the ASME A17.1/CSA B44 Code.

2.1.1.2

Section 1.2 of the ASME A17.1/CSA B44 Code allows use of systems, methods, or devices of equivalent or superior quality, strength, fire resistance, effectiveness, durability, and safety to those prescribed by the ASME A17.1/CSA B44 Code provided that there is technical documentation or physical performance verification that will assure safety equivalent to that which would be provided by conforming to the corresponding requirements of ASME A17.1/CSA B44.

2.1.2 ASME A17.7/CSA B44.7 Process

2.1.2.1

This Code provides an alternative process to the ASME A17.1/CSA B44 Code for establishing elevator safety. It includes a structured methodology for establishing, documenting, and demonstrating that necessary and appropriate protective measures are taken to eliminate hazards or sufficiently mitigate risks. This process is particularly useful for establishing safety of elevator systems, sub-systems, components, or functions involving innovative design and new technologies.

2.1.2.2

The process is based on a structured application of GESRs.

NOTE (2.1.2.2): *Part 3 contains GESRs. Nonmandatory Appendix A gives background on their development and the process for using them. For more detail on GESRs, refer to ISO/TS 22559-1.*

2.1.2.3

A GESR states only the safety objective, or “what” shall be done or accomplished, but not “how” to accomplish the objective. To accomplish the safety objective of a GESR, elevator systems, sub-systems, components, or functions and SPs that are used shall be capable of eliminating or sufficiently mitigating safety risks addressed in the GESR.

NOTE (2.1.2.3): *Nonmandatory Appendix B-1 contains the SPs in relation to the specific GESRs. An SP may be specified in the form of SILs, clearances, strength, durability, acceleration or retardation values, etc.*

2.1.2.4

To verify and demonstrate that an elevator system, sub-system, component, or function complies with the safety objectives of an applicable GESR, risk assessment is carried out and the results documented.

NOTE (2.1.2.4): *Section 2.7 and Nonmandatory Appendix C give basic information on available risk assessment methods, including more details and templates for use in relation to the method specified in ISO 14798.*



2.1.2.5

After the subject of the risk assessment has been defined (2.3), applicable GESRs identified (2.4 and 2.5) and implemented (2.6), risk assessment conducted (2.7), and identified risks sufficiently mitigated by implementing protective measures (2.8) and SPs (2.9) where appropriate, a CCD shall be produced (2.10) to be subjected to a conformity assessment process.

NOTE (2.1.2.5): *Mandatory Appendix I gives details on the certification procedures used by AECOs.*

2.1.3 Equivalency of Processes

Compliance with the ASME A17.1/CSA B44 Code is a recognized de-facto means for meeting applicable ASME A17.7/CSA B44.7 GESRs without further verification.

SECTION 2.2 OPTIONS FOR ESTABLISHING SAFETY

2.2.1

The safety of an elevator system, sub-system, component, or function shall be established by one of the following processes:

- (a) Option 1 — Conform to the requirements in ASME A17.1/CSA B44;
- (b) Option 2 — Conform to some of the requirements in ASME A17.1/CSA B44 and for elevator systems, sub-systems, components, or functions that do not conform to certain requirements in ASME A17.1/CSA B44, conform to the applicable requirements in this Code; or
- (c) Option 3 — Conform to the requirements in this Code.

NOTES (2.2.1):

- (1) *Option 1 is the conventional process used by implementing the ASME A17.1/CSA B44 Code.*
- (2) *Option 2 is the most common process for innovative design or use of new technology. The elevator system, sub-system, component, or function will typically meet most requirements of ASME A17.1/CSA B44; however, it may have certain design or other features or components not covered by, or which deviate from, ASME A17.1/CSA B44 prescriptive requirements but conform to applicable GESRs in Section 3.*
- (3) *Option 3 provides the alternative of achieving safety by satisfying all the applicable GESRs in Section 3. The option is useful when the elevator system, sub-system, component, or function is radically different from that addressed by ASME A17.1/CSA B44 requirements. In this case, all applicable requirements of the GESRs must be met.*

2.2.2

This Code establishes the process for implementation of Options 2 and 3.

NOTE (2.2.2): *In the case of Option 1, requirements of ASME A17.1/CSA B44 fully apply.*

SECTION 2.3 SAFETY ASSESSMENT SUBJECT

2.3.1

The safety assessment subject (such as an elevator system, sub-system, component, or function or installation, maintenance, operation, and use, throughout the life cycle of the elevator) shall be clearly described. If the subject is a range of products, such range shall be specified.

EXAMPLES (2.3.1):

- (1) *Example of an elevator system to be assessed – Elevator without a machine room.*
- (2) *Example of a range of products – Duty loads, operating speeds, rise, and other relevant characteristics.*



2.3.2

It is only necessary to describe the particular characteristics of the system that impact safety of the system.

EXAMPLE (2.3.2): *If the design relates to an elevator car door, the speed or rise of the elevator and other elevator features may not be relevant. In such case, the sole subject of analysis and assessment will be the car door.*

2.3.3

The described elevator system, sub-system, component, or function shall be identified by documentation, including drawings and specifications, and installation, testing, and operational instructions, etc., that uniquely characterize the equipment to be assessed for safety. Documentation shall also provide information to enable identification of the elevator system, sub-system, component, or function once installed in the field.

NOTE (2.3.3): *See Section 2.10 for documentation requirements.*

SECTION 2.4

ASSURING SAFETY BY IMPLEMENTING GESRs

2.4.1 Introduction

GESRs for elevators are listed in Part 3. They are grouped on the basis of locations where a person could be exposed to a hazard, hazardous situation, or harmful event, as follows:

- (a) at different locations (3.1);
- (b) adjacent to the elevator (3.2);
- (c) at the elevator entrance (3.3);
- (d) inside LCU (car) (3.4); and
- (e) working areas (3.5).

NOTES (2.4.1):

- (1) *Nonmandatory Appendix A-1 provides information on the approach and methodology used by ISO in developing and formulating GESRs.*
- (2) *Nonmandatory Appendix A-2 provides information on the selection and implementation of GESRs in relation to the new elevator systems, sub-systems, components, or functions and the steps towards obtaining a Certificate of Conformance.*
- (3) *Nonmandatory Appendix A-3 is provided to give users an overview of GESRs in relation to elevator sub-systems to which GESRs apply or could apply.*
- (4) *Nonmandatory Appendix A-4 is provided as a method of selecting applicable GESRs.*

2.4.2 Identification of Applicable GESRs

2.4.2.1 Possible Approaches

When assessing safety of an elevator system, sub-system, component, or function, the applicability of GESRs shall be determined by the approach in 2.4.2.2 or 2.4.2.3.

NOTE (2.4.2.1): *For more details, see A-2.2 in Nonmandatory Appendix A-2.*

2.4.2.2 Approach 1 – Preliminary Review of All GESRs

2.4.2.2.1

GESRs in Part 3 shall be reviewed to identify those that could be applicable to the subject being assessed for safety. Selection of applicable GESRs shall be consistent with the scope and range of the application to the described elevator system, sub-system, component, or function.



2.4.2.2.2

If conformance with applicable GESRs is not self-evident, risk assessment shall be completed to demonstrate conformance. (See 2.7 and Nonmandatory Appendix C.)

NOTE (2.4.2.2): For this purpose, a copy of the template provided in Nonmandatory Appendix A-4 can be used. The template is identical to the table in Nonmandatory Appendix A-3, except that two more columns are added — column “Ap” to identify that the GESR in the corresponding row is or may be applicable to the subject of risk assessment, and column “RA” to enter the risk assessment case identification to document compliance with the relevant GESR, or alternatively the ASME A17.1/CSA B44 Code reference requirement when full compliance is achieved by meeting such requirements. Nonmandatory Appendix E-2 is an example of use of the template.

2.4.2.2.3

GESRs shall be sorted as specified in 2.5.

2.4.2.3 Approach 2 – Risk Scenarios

2.4.2.3.1

Risk scenarios that could occur during operation and use, as well as during maintenance, inspection, and testing of the elevator system, sub-system, component, or function throughout its life cycle, shall be developed and formulated. Each scenario shall include a description of hazardous situations, possible causes, and effects (2.7.3).

2.4.2.3.2

Risk assessment for each scenario shall be completed (see 2.7 and Nonmandatory Appendix C).

2.4.2.3.3

GESR(s) with which compliance would eliminate or sufficiently mitigate the risk shall be identified.

NOTE (2.4.2.3): For abbreviated examples of formulation of risk scenarios, see Nonmandatory Appendix Table A-1. For a comprehensive list of, and examples for, elevator-related hazards, hazardous situations, causes, and effects, refer to Nonmandatory Appendix Tables D-1 to D-4. For “Risk assessment template”, see Nonmandatory Appendix C. For examples of use of this template, see Nonmandatory Appendix E-2.

SECTION 2.5

SORTING OF APPLICABLE GESRS FOR APPROACH 1

2.5.1

GESRs identified as potentially applicable (2.4.2.2.2) to the subject being assessed for safety shall be examined to determine which GESR, if any

- (a) could be fully complied with by conforming to requirements specified in the ASME A17.1/CSA B44 Code. Such GESRs shall be identified in the documentation (see Section 2.10) with the applicable ASME A17.1/CSA B44 requirement number(s); or
- (b) could not be fully complied with by application of ASME A17.1/CSA B44 requirements.

2.5.2

Verification of conformance to GESRs, referred to in 2.5.1(b), shall be carried out in accordance with Section 2.6.



SECTION 2.6 IMPLEMENTATION OF GESRs

2.6.1

If conformance with applicable GESRs is not self-evident, conformance of an elevator system, sub-system, component, or function with applicable GESRs shall be demonstrated through the risk assessment process in accordance with Section 2.7.

2.6.2

Safety of an elevator system, sub-system, component, or function is achieved when

- (a) all risk scenarios related to the subject of assessment are identified and formulated;
- (b) risk assessment is conducted in accordance with Section 2.7;
- (c) appropriate SPs (see Part 4 and Nonmandatory Appendix B-1) are implemented; and
- (d) this process comes to the conclusion that the requirements of applicable GESRs and applicable SPs have been met, i.e., hazards identified in the scenarios have been eliminated or safety risks sufficiently mitigated.

NOTE (2.6): *Nonmandatory Appendix A-2 gives comprehensive instructions on implementation of GESRs, with examples illustrating the process. Nonmandatory Appendix A-2.3.2 is relevant to the use and application of GESRs by the elevator designer, manufacturer, installer, maintenance, and service organizations. Nonmandatory Appendix A-2.3.3 addresses use by conformity assessment bodies (AECOs), and Nonmandatory Appendix A-2.3.4 relates to inspection and testing bodies.*

SECTION 2.7 RISK ASSESSMENT PROCESS

2.7.1 Risk Assessment Methodologies

Section 2.7 describes the use of an RA methodology based on ISO 14798, although other methodologies for analyzing hazards and estimating risks are equally acceptable. Nonmandatory Appendix C also addresses the use of ISO 14798. For users of this ISO methodology, the following is provided in Nonmandatory Appendix C:

- (a) Table C-1 – Risk assessment template;
- (b) Tables C-2.1 and C-2.2 – Criteria for estimation of risk elements, i.e., levels of severity and probability;
- (c) Tables C-3.1 and C-3.2 – Risk estimation and evaluation; and
- (d) Table C-4 – Guide for moderators of risk assessment teams.

2.7.2 Risk Assessment Team

A substantially balanced team of qualified members who collectively have experience in the design, manufacture, installation, maintenance, inspection, and testing of elevators shall be formed to conduct the risk assessment. Users of the methodology do not make medical judgments but, rather, evaluate events that could lead to levels of severity of harm described in this document. The team shall be led by a moderator who is well versed and experienced in elevator technology and in the application of ISO 14798 or equivalent methodologies for analyzing hazards and estimating risks.

NOTE (2.7.2): *Risk assessment made by an individual may not be as comprehensive as that carried out by a team and is not an acceptable alternative to the balanced team.*



2.7.3 Risk Scenario

Risk scenarios shall be formulated by describing hazardous situations and potential harmful events resulting from the causes, effects, and levels of harm. This identifies risks with respect to a specific design of an elevator system, sub-system, component, or function, or risks with respect to installation, operation, use, maintenance inspection, or testing, or whatever the subject of the risk assessment.

NOTES (2.7.3):

- (1) For abbreviated examples of formulation of risk scenarios, see Nonmandatory Appendix Table A-1.
- (2) For a comprehensive list of, and examples for, elevator-related hazards, hazardous situations, causes, and effects, refer to Nonmandatory Appendix Tables D-1 to D-4.
- (3) For a Risk Assessment Template that could be used to formulate risk scenarios, to estimate risk elements, and record protective measures, see Nonmandatory Appendix C.
- (4) For examples of use of this template, see Nonmandatory Appendix E-2.

2.7.4 Risk Estimation and Evaluation

2.7.4.1 Risk Estimation

2.7.4.1.1

Based on the formulated risk scenario, elements of risk are estimated by

- (a) the level of severity of effect (or harm), by using Nonmandatory Appendix Table C-2.1; and
- (b) the level of probability of the occurrence of that effect or harm, by using Nonmandatory Appendix Table C-2.2.

2.7.4.1.2

In determining the potential level of harm, the team shall articulate in technical terms potential effects of the event on individuals exposed to the hazard (for example, subject to acceleration, KE, shearing, crushing, abrasion, etc.).

2.7.4.1.3

The results are recorded in the first set of S/P columns in the Nonmandatory Appendix C risk assessment template.

NOTES (2.7.4.1):

- (1) For an example of a Risk Assessment Template that could be used to record the estimated risk elements, see columns "S" and "P" in Nonmandatory Appendix C.
- (2) For examples of levels of risk elements in this template, see columns "S" and "P" in Nonmandatory Appendix E-2.

2.7.4.2 Risk Evaluation

The steps taken to this point [i.e., formulation of the scenario (hazardous situation, cause, and effect) and assignment of initial levels of severity and probability] constitute the risk analysis portion of the RA. To estimate the level of risk, the combination of estimated levels of severity and probability determined in the risk analysis is evaluated against Nonmandatory Appendix Table C-3.1. The estimated risk will determine whether further protective measures shall be taken based on the Risk Groups in which the estimated risk level falls as follows:

- (a) Risk Group I requires that further protective measures are necessary to satisfy the GESR and the process shall continue in accordance with Section 2.8.
- (b) Risk Group II requires a review to determine if any further protective action is needed, taking into account the practicability of the solution and societal value.
- (c) Risk Group III requires no further action.

NOTE (2.7.4.2): For Risk Groups, see Nonmandatory Appendix Table C-3.2.

EXAMPLE (2.7.4.2): According to Nonmandatory Table C-3.2, for risk level 2C which falls into Risk Group I, further protective measures would be required. For risk level 3E which falls into Risk Group III, no further action is required.



2.7.4.3 Risk Assessment Records

Results of risk identification (risk scenarios), risk estimation, and evaluation processes, as well as designation of protective measures (see Section 2.8), which can include selection of appropriate SPs (see Section 2.9) taken to mitigate or eliminate a risk, shall be documented (see Section 2.10).

NOTE (2.7.4.3): Copies of templates in Nonmandatory Appendix C could be used for this purpose.

SECTION 2.8 PROTECTIVE MEASURES AND SAFETY PRINCIPLES

2.8.1 Protective Measures

Where risk evaluation completed in accordance with 2.7.4.2 concludes that the level of risk requires mitigation, protective measures shall be implemented in the following order:

- (a) Eliminate the hazard, where possible, by revisions to the design.
- (b) If the identified hazard cannot be eliminated in accordance with 2.8.1(a), further measures shall be taken to reduce the risk. These measures include:
 - (1) re-designing equipment to increase its reliability;

EXAMPLE [2.8.1(b)(1)]: Measures to increase reliability may include increasing safety factors or introducing redundancy and checking redundancy for components prone to failures, such as electromagnetic relays, electronic and software components, braking systems, etc.

- (2) reducing the frequency and/or duration of exposure of persons to hazard;

EXAMPLE [2.8.1(b)(2)]:

- (1) Reducing frequency of exposure of elevator personnel by the use of equipment or components that require low or no maintenance.
- (2) Reducing the frequency of exposure of users to door impact by the use of suitable door reopening devices.

- (3) altering procedures for use, service, cleaning, etc.;
- (4) adding protective or safety devices, to act if an elevator system, sub-system, component, or function fails; or

EXAMPLE [2.8.1(b)(4)]: Protective devices include devices similar to safeties, buffers, emergency brakes, interlocks etc.

- (5) adding guards to separate persons from hazardous equipment or spaces.

EXAMPLE [2.8.1(b)(5)]: Hoistway enclosures to separate elevator equipment from areas accessible to the general public; covers on rotating or moving parts to protect mechanics from inadvertent contact, etc.

- (c) Eliminate or minimize the probability of defeat or circumvention of protective measures, such as guards, safety devices, etc.

NOTE [2.8.1(c)]: See examples of formulation of protective measures and subsequent estimation of risk elements in the second set of "S/P" columns, as well as the comments on residual risk in the last columns, in Nonmandatory Appendix Table E-2.4.

- (d) If the identified hazard cannot be mitigated in accordance with 2.8.1(a), (b) and (c), inform users and authorized personnel of residual risks by one or more of the following protective measures:
 - (1) information;
 - (2) training;
 - (3) warning signs;
 - (4) use of personal protection equipment, etc.



2.8.2 Verification of Safety Implications of the Implemented Protective Measures

When the template in Nonmandatory Appendix Table C-1 is used, unless it is evident that implementation of a protective measure cannot create a new hazard, a new risk assessment, in accordance with 2.7.3 and 2.7.4, shall be conducted. If there is a residual risk that requires further mitigation, there are two acceptable methods of documentation:

- (a) create a new case and case number directly under the case that created it. Complete the assessment until the remaining risks have been sufficiently mitigated; or
- (b) create a new case and case number in the section of the document where the GESR pertaining to the new hazard is listed and refer back to the origin of the initial case that generated the new case.

2.8.3 Safety Principles

2.8.3.1

The following principles shall be observed when providing measures for elimination or reduction of risks on elevators.

2.8.3.2

When the system is operating, there shall be no risk of the level equivalent to those categorized in Nonmandatory Appendix Table C-3.2 as "Risk Group I". In the case of a risk of the level equivalent to those identified as "Risk Group II", a review shall be carried out to determine if any further protective measure is required. In the case of a risk of the level equivalent to those identified as "Risk Group III", no further action is required.

2.8.3.3

System design shall require positive action(s) to be taken in a prescribed manner to either begin or continue system operation.

2.8.3.4

System safety in the normal automatic operating mode shall not depend on correct actions or procedures used by operating personnel.

2.8.3.5

Maintenance, including periodic inspections and testing activities required to preserve or achieve risk levels, shall be identified.

SECTION 2.9 APPLICATION OF SPs

2.9.1

The determination that a risk has been sufficiently mitigated will sometimes require that specific safety parameter values be achieved (such as reliability, strength, durability, clearances, acceleration or retardation values). Safety parameter values are provided in Nonmandatory Appendix B, and their application is described in Part 4.

2.9.2

Where measures different from the SPs or SP values in Nonmandatory Appendix B-1 are used, the RA shall demonstrate that the risk(s) identified in the GESR has been sufficiently mitigated to safety levels equivalent to those that would be obtained using the safety parameters in Nonmandatory Appendix B.



SECTION 2.10 CODE COMPLIANCE DOCUMENTATION

2.10.1

A CCD shall be produced for each design of an elevator system, sub-system, component, or function for which safety has been assessed for conformance with this Code.

2.10.2

The CCD shall include the following:

- (a) an overall description of the equipment;
- (b) a description of a particular elevator system, sub-system, component, or function to which this Code is being applied;
- (c) a list of ASME A17.1/CSA B44 Parts, Sections, or requirements that have been addressed by compliance with ASME A17.7/CSA B44.7;
- (d) the technical documentation necessary to demonstrate conformity and enable verification of conformance;
- (e) a list of GESRs considered in accordance with Section 2.5;
- (f) the risk assessment report, including team members, their relevant expertise and experience, and date of completion of the risk assessment processes (see Sections 2.3 through 2.7);
- (g) procedures for acceptance inspections and tests to verify conformance with the CCD; and
- (h) procedures for tests, periodic inspections, maintenance, replacements, adjustments, and repairs to be incorporated into and made a part of the MCP required by ASME A17.1/CSA B44, requirement 8.6.1.2.1.

SECTION 2.11 CODE DATA PLATE

2.11.1

A Code Data Plate complying with ASME A17.1/CSA B44, Section 8.9, shall be provided.

2.11.2

The Code Data Plate shall include the following statement: "This elevator complies with ASME A17.7/CSA B44.7. See Maintenance Control Program."

NOTE (2.11.2): See also Mandatory Appendix I-6 for marking of elevator systems, sub-systems, and components.

SECTION 2.12 ADDITIONAL REQUIREMENTS

2.12.1

Design and installation shall comply with the CCD (2.10) and applicable requirements of ASME A17.1/CSA B44, Section 8.1.

2.12.2

Alterations, maintenance, repair, and replacement shall comply with the CCD (2.10) and applicable requirements of ASME A17.1/CSA B44, Sections 8.6 and 8.7. The list of applicable ASME A17.1/CSA B44 requirements that have been addressed by compliance with ASME A17.7/CSA B44.7 shall be incorporated into and made a part of the MCP required by ASME A17.1/CSA B44, requirement 8.6.1.2.1.



2.12.3

Acceptance and periodic inspections and tests shall comply with the CCD (2.10) and applicable requirements of ASME A17.1/CSA B44, Sections 8.10 and 8.11. Procedure for tests, periodic inspections, maintenance, replacements, adjustments, and repairs shall be incorporated into and made a part of the MCP required by ASME A17.1/CSA B44, requirement 8.6.1.2.1.



PART 3

GLOBAL ESSENTIAL SAFETY REQUIREMENTS (GESRs) FOR ELEVATORS

Elevators shall comply with the applicable safety requirements specified in this Part.

NOTES (3):

- (1) *The GESRs and the process of their development and use have been derived from ISO/TS 22559-1. Adaptations have been made for North American terminology. Additionally, ISO/TS 22559-1 has been modified to cover the scope of this Code.*
- (2) *The essential safety requirements are grouped in this Part on the basis of locations where a person could be exposed to a hazard, hazardous situation, or harmful event. These locations include the space adjacent to the elevator (see 3.2), entrance and egress areas (3.3), space inside the LCU (car) (3.4) and working areas (3.5). The common requirements, which are applicable to more than one location, are listed in 3.1.*
- (3) *Nonmandatory Appendix A-3 is provided to give an overview of the GESRs that are potentially applicable to the elevator sub-systems.*

SECTION 3.1

COMMON GESRs RELATED TO PERSONS AT DIFFERENT LOCATIONS

3.1.1 Supports for Elevator Equipment

The means used to support the elevator equipment shall be capable of sustaining all loads and forces (including impact forces) imposed during normal and emergency operation.

NOTE (3.1.1): *The forces referred to in 3.1.1 are those that result from the intended use, and reasonably foreseeable overload, of the elevator during normal operation (loading, unloading, acceleration, braking, etc.) and emergency operation (safety operation, buffer impact, etc.).*

3.1.2 Elevator Maintenance

Where maintenance is required to ensure continued safety, appropriate instructions shall be provided, and elevator personnel shall perform any required work.

NOTE (3.1.2): *This applies to the elevator system, sub-system, component, or function that is subject to wear and tear, not to those designed for maintenance-free operation. Adequate maintenance is a key element in keeping the elevator in safe operating condition. The objective of this GESR is to require that only elevator personnel perform maintenance work.*

3.1.3 Equipment Inaccessible to Users and Non-Users

Equipment that is hazardous shall not be directly accessible to users and non-users.

NOTE (3.1.3): *Locations that are not accessible include equipment behind an enclosure, a locked cover or door, or in an out-of-reach location.*

3.1.4 Floors of the LCU (Car) and Working Areas

The floors of the LCU (car) and standing areas of workplaces shall minimize the risk of tripping and slipping.

NOTE (3.1.4): *LCU (car) and working area floors should be reasonably level, which means that they do not present a perceptible slope. When considering non-slip materials, attention should be paid to the fact that the roughness of a material does not remain consistent over time and can vary depending on housekeeping operations (e.g., cleaning).*



3.1.5 Hazards Due to Relative Movement

Users and non-users shall be protected from the effects of shearing, crushing or abrasion, or other injuries due to

- (a) relative movement of the LCU (car) and external objects; and
- (b) relative movement of the elevator equipment.

NOTES (3.1.5):

- (1) For elevator personnel, see 3.5.9.
- (2) This GESR addresses the safety of persons located inside and outside the LCU (car).

3.1.6 Locking Landing Doors and Closing LCU (Car) Doors

Any movement of the LCU (car) that is hazardous to persons shall be stopped if any hoistway door is open or unlocked or the LCU (car) door is not closed.

NOTES (3.1.6):

- (1) Hoistway and car doors, including auxiliary doors or covers intended for use by elevator personnel only (e.g. evacuation doors), must be considered.
- (2) Leveling, re-leveling (as well as truck load operation), and hoistway access operation are not considered to be hazardous movements.

3.1.7 Evacuation

Means and procedures shall be provided to enable trapped users or elevator personnel to be safely released and evacuated.

NOTE (3.1.7): The elevator system should have means that would permit the movement of the LCU (car), under control of elevator personnel, to the point of an evacuation opening. Alternative means that do not require movement of the LCU (car) are not excluded. Extreme cases of LCU (car) blockage (due to safety setting, material damaged due to earthquakes, etc.) can require external means, appropriate instructions, and tooling.

3.1.8 Sharp Edges

Means shall be provided to sufficiently mitigate the risk to users and non-users of exposure to sharp edges.

NOTE (3.1.8): For elevator personnel, see 3.5.

3.1.9 Hazards Arising from the Risk of Electrical Shock

Where electricity is provided, means shall be provided to sufficiently mitigate the risk to users and non-users of exposure to electrical shock and related hazards.

NOTES (3.1.9):

- (1) CSA B44.1/ASME A17.5, ANSI/NFPA 70, and/or CSA C22.1 embody the fundamental principles of protection for safety that encompass protection against electric shock, protection against thermal effects, protection against overcurrent, protection against fault current, and protection against over-voltage. See also Section 131 of IEC 60364-1.
- (2) For elevator personnel, see 3.5.

3.1.10 Electromagnetic Compatibility

The safe operation of an elevator shall not be influenced by electromagnetic interferences.

NOTE (3.1.10): The immunity should be sufficient to prevent unsafe situations if the elevator is submitted to foreseeable radiation. "Immunity" includes immunity to internal influences (self-generated radiation) and immunity to external influences.



3.1.11 Illumination of LCU (Car) and Landings

The LCU (car) and landings shall be provided with adequate illumination during use.

NOTE (3.1.11): "Adequate illumination" means that the level of light is sufficient for safe access and operation of the elevator control devices, including the following:

- (a) detecting leveling inaccuracy;
- (b) operating landing and LCU (car) controls; and
- (c) mitigating user's panic in the case of power outage.

3.1.12 Effects of Earthquake

In areas subject to earthquake, means shall be provided to minimize the risk to users, when inside the LCU (car), and elevator personnel of the foreseeable effects of earthquakes on the elevator equipment.

NOTE (3.1.12): The effects on the safety of users and elevator personnel need to be considered at all stages: during the earthquake (as much as possible), during rescue from a stalled LCU (car), and when the elevator is returned to normal operation. This assumes that there is no major building failure.

3.1.13 Hazardous Materials

The characteristics and quantity of material used for the manufacture and construction of the elevator shall not lead to hazardous situations.

NOTE (3.1.13): Hazardous situations for users, non-users, and elevator personnel refer to toxicity, fumes, exposure to chemicals, flammability, exposure to asbestos, etc.

3.1.14 Environmental Influences

Users and elevator personnel shall be protected from environmental influences.

NOTE (3.1.14): Environmental influences include the foreseeable weather conditions of the area where the elevator is installed. Users and elevator personnel should be protected against direct exposure to the influences (e.g., by heating or cooling the LCU (car) or working space). The safety of users, elevator personnel, and emergency personnel should be considered in the event of a fire. In addition, there should be adequate protection of safety-related elevator elements that are susceptible to weather conditions.

SECTION 3.2

GESRs RELATED TO PERSONS ADJACENT TO THE ELEVATOR — FALLING INTO HOISTWAY

Means shall be provided to prevent the risk of users, non-users, and elevator personnel falling into the hoistway.

NOTES (3.2):

- (1) This GESR addresses the risk of falling into the hoistway from
 - (a) surrounding floors; and
 - (b) landing doors when the LCU (car) is absent.
- (2) This GESR also applies to emergency personnel.



SECTION 3.3

GESRs RELATED TO PERSONS AT THE ELEVATOR ENTRANCE

3.3.1 Access and Egress

Safe means of access and egress shall be provided to the LCU (car) at landings.

NOTE (3.3.1): This is applicable to the process of entering and leaving the LCU (car) during normal use and during Firefighters' Emergency Operations of the elevator. It suggests that adequate spaces, dimensions, operational instructions and correct relative positioning of the LCU (car) at the landing should be provided.

3.3.2 Horizontal Sill-to-Sill Gap

The horizontal gap between the sill of the LCU (car) and that of the landings shall be limited.

NOTE (3.3.2): The measurement is taken in the direction of motion of users traversing the sill. Children who are able to walk should be considered. The sizes of wheelchair wheels and walking aids should also be taken into account.

3.3.3 Alignment of LCU (Car) and Landing

When users enter or exit the LCU (car), its platform and landing floor shall be substantially aligned.

NOTE (3.3.3): The step caused by the variation of the LCU (car) load should be limited to avoid stumbling on the part of users; the step should be small enough to allow safe access for all users, including persons with impaired mobility.

3.3.4 Self-Evacuation from an LCU (Car)

Self-evacuation of users shall be possible only when the LCU (car) is at or near a landing.

NOTE (3.3.4): "Near a landing" means that the LCU (car) is not too far away from the landing and that the risk of tripping or falling is minimal. Furthermore, any gaps between the LCU (car) entrance opening, when the LCU (car) entrance is opened manually by users attempting self-evacuation, and the hoistway enclosure or the landing entrance, which faces the opened LCU (car) entrance, should be as small as possible to prevent users from passing through the gaps and from falling into the hoistway.

3.3.5 Gap between the Landing Doors and LCU (Car) Doors

The space between the landing doors and LCU (car) doors shall not allow the presence of users.

NOTE (3.3.5): This GESR aims to prevent persons, including children, from entering into the space between the LCU (car) and landing doors. The following are examples where this situation can arise:

- (a) multiple panels on the LCU (car) and landing doors, with loose synchronization; or
- (b) combinations of swing landing doors and sliding LCU (car) doors.

3.3.6 Means to Reopen Doors when LCU (Car) is at Landing

Means shall be provided to reopen the LCU (car) and landing doors if their closing is obstructed when the LCU (car) is at the landing.

NOTE (3.3.6): Obstacles interfering with door movement should be detected. The movement of the doors and the LCU (car) should be prevented until the obstacle is removed or door closing speed and force is limited. Examples of obstacles are parts of a user's body, trolleys, wheelchairs, etc.



SECTION 3.4 GESRs RELATED TO PERSONS IN THE LCU (CAR)

3.4.1 Strength and Size

The LCU (car) shall accommodate and support the rated load and a reasonably foreseeable overload.

NOTE (3.4.1): This GESR is primarily addressing transportation of people. "Accommodate" in this context means to provide space (volume) for the intended number of users, considering the dimension and weight of persons. The foreseeable overload, in terms of users, means:

- (a) the load normally carried by users (e.g., briefcase, luggage, but without tools such as trolleys);
- (b) the possibility of users taller or heavier than average; and
- (c) the possibility of more users than the LCU (car) is designed for.

3.4.2 LCU (Car) Support/Suspension

Means shall be provided to support the fully loaded LCU (car) and a reasonably foreseeable overload.

NOTE (3.4.2): This addresses the strength and failure of the suspension means, when the LCU (car) is loaded with its rated load. It is, however, understood that the integrity of the elevator would be maintained if the foreseeable overload condition were reached. The rated performances, however, can be affected if the rated load is exceeded.

3.4.3 Overloaded LCU (Car)

Means shall be provided to prevent an overloaded LCU (car) from attempting to leave a landing.

NOTE (3.4.3): In this context "to prevent from attempting to leave a landing" means that the drive system (motor controller) of the hoisting machine will not be activated. When the overload condition is detected, no command will be processed. This does not cover rope stretch, loss of traction, etc. It is, however, understood that the integrity of the elevator would be maintained if the foreseeable overload condition were reached.

3.4.4 Falling from an LCU (Car)

Means shall be provided to prevent users from falling from the LCU (car).

NOTE (3.4.4): Compliance with this GESR can be achieved by guards, barriers, or walls around the perimeter of the LCU (car) platform. Protection at any opening between the LCU (car) and the hoistway walls that a user could pass through is also required by this GESR. A typical opening is the gap between the edges of the LCU (car) and the landing door panels.

3.4.5 LCU (Car) Travel Path Limits

The vertical travel of the LCU (car) shall be limited to prevent the LCU (car) from uncontrolled running beyond the travel path.

NOTE (3.4.5): Means should be provided for safe stopping of the LCU (car) at the end of the travel path. Safe stopping involves no damage to the equipment and no harm to passengers in the LCU (car). The "end of travel path" includes a certain overrun from the terminal landing position.

3.4.6 Uncontrolled, Unintended Movement of an LCU (Car)

Means shall be provided to limit uncontrolled or unintended movement of the LCU (car).

NOTE (3.4.6): This GESR aims to protect against the effects resulting from the movement of the LCU (car) at a speed exceeding the designed speed and also to prevent effects resulting from unexpected starts of LCU (car) movement. Examples of such occurrences are: travel of the LCU (car) towards terminal landings at a speed exceeding its rated speed, or movement of the LCU (car) away from a landing when doors are open and users are entering or exiting. An example of the foreseeable failures that can cause such occurrences is the breakdown in elevator components such as speed control, driving machine, or braking system. Such failures could occur as a result of mechanical or electrical control malfunctions.



3.4.7 LCU (Car) Collision with Objects in or beyond Travel Path

Means shall be provided to avoid collision of the LCU (car) with any equipment in the travel path that could cause injuries to users.

NOTE (3.4.7): Means should be provided to prevent the LCU (car) from colliding with any equipment in the hoistway. There should be LCU (car) guards or enclosures of adequate strength to avoid dangerous deflection due to horizontal forces. Deflection and deformation of the guards or enclosure should be limited so that they do not create a hazardous situation. This GESR also addresses cases where the LCU (car) or counterweight reaches the structural terminals of the hoistway. Eventual impact should be buffered so that it is not harmful.

3.4.8 LCU (Car) Horizontal and Rotational Motion

Horizontal or rotational motion of the LCU (car) shall be limited to sufficiently mitigate the risk of injury to users and elevator personnel.

NOTE (3.4.8): Horizontal and rotational free movement of the LCU (car) is to be limited to prevent users from losing balance and falling.

3.4.9 Change of Speed or Acceleration

Means shall be provided to ensure that any change of speed or acceleration of the LCU (car) shall be limited to minimize the risk of injury to the users.

NOTE (3.4.9): This covers changes of speed and acceleration of the LCU (car) for both normal and emergency operations. In the case of an extreme emergency [such as stopping a free-falling LCU (car)], the possibility of minor injuries could be tolerated, due to the extremely remote probability of such an occurrence.

3.4.10 Objects Falling on the LCU (Car)

LCU (car) users shall be protected from falling objects.

NOTE (3.4.10): Falling objects are those that can be reasonably expected as a result of misbehavior, carrying tools, or similar activities. Open hoistway installations can also be subject to acts of vandalism (objects thrown from outside). Falling water is not addressed by this GESR.

3.4.11 LCU (Car) Ventilation

Adequate ventilation shall be provided to the LCU (car).

NOTE (3.4.11): The intent of this GESR is to provide trapped passengers with sufficient air renewal. It is accepted that normal operation does not require particular measures due to the air exchange from door movement and the fact that journeys are relatively short.

3.4.12 Fire/Smoke in LCU (Car)

The interior of the LCU (car) shall be constructed of materials that are fire-resistant and that develop a low level of smoke.

NOTE (3.4.12): The nature and quantity of the materials used in the LCU (car) (e.g., decorations) can be a serious source of harm during a fire. Factors that need to be considered include fire resistance, toxicity, etc., of materials. It is, however, understood that parts made of materials that do not strictly meet this specification may be used in small quantities inside the LCU (car) (e.g., control buttons and lighting diffusers).

3.4.13 LCU (Car) in Flooded Areas

Where there is a risk that the LCU (car) will descend into a flooded area, means shall be provided to detect and prevent descent into a flooded area.



3.4.14 Stopping Means Inside the LCU (Car)

Means located inside the LCU (car) of intentionally interrupting the movement of the LCU (car) by the user shall be allowed only, if necessary, on elevators with a partially enclosed LCU (car) or elevators for special applications.

NOTE (3.4.14): *An example of an elevator for special application is a freight elevator with truck-zone operation.*

3.4.15 Landing Indication

Means shall be provided to identify landings for the users in the LCU (car).

NOTE (3.4.15): *Ignorance of one's location can create confusion and unpredictable reactions. In normal conditions, this is probably not a safety issue but it can be significant in emergencies (firefighting, etc.).*

SECTION 3.5

GESRs RELATED TO PERSONS IN WORKING AREAS

3.5.1 Working Space

Adequate and safe working space shall be provided.

NOTE (3.5.1): *"Adequate" takes into account the ergonomics principles related to the tasks to be performed.*

3.5.2 Accessible Equipment

All elevator equipment requiring maintenance shall be safely accessible to elevator personnel.

NOTE (3.5.2): *If elevator elements requiring maintenance are not accessible, they can be neglected, which would render use of the installation unsafe. Elements of the elevator should be designed taking this into account. "Safely" indicates safe and easy access for maintenance operations.*

3.5.3 Access to and Egress from Working Spaces in the Hoistway

Access to and egress from working spaces in or beyond the travel path shall be safe.

NOTE (3.5.3): *Egress from any working space should always be possible, regardless of the position of the LCU (car). Working spaces include the LCU (car) roof.*

3.5.4 Strength of Working Areas

Means shall be provided to accommodate and support the weight of elevator personnel and associated equipment in any designated working area.

NOTE (3.5.4): *The number of elevator personnel and the equipment that they carry or use to fulfil the anticipated working activities should be determined. Those activities do not include major repairs when the working area needs to be enlarged and reinforced.*

3.5.5 Restrictions on Equipment in Elevator Spaces

Only equipment related to the elevator installation or its protection shall be placed in the space containing the elevator equipment.

NOTE (3.5.5): *The intent is to exclude non-elevator personnel (and personnel not acquainted with the dangers of elevator operation) from access to spaces needed for the location of the elevator equipment (the machine room, machine space, control room, control space, and hoistway) and to prevent the use of these spaces for storage.*



3.5.6 Falling from Working Areas

Means shall be provided to sufficiently mitigate the risk to elevator personnel of falling from any working area.

NOTES (3.5.6):

- (1) Working places in the hoistway, such as the LCU (car) roof, temporary platforms, etc., should be equipped with protective devices (e.g., a standard railing), if there is a risk of falling (e.g., a gap between the LCU (car) roof and the hoistway wall).
- (2) The means of prevention (e.g., standard railing) should have sufficient height and strength.

3.5.7 LCU (Car) Movement under Control of Elevator Personnel

Only elevator personnel shall be provided with means to prevent or to enable the movement of the LCU (car) when they are in the travel path. When elevator personnel are within reach of unprotected moving parts of the elevator, they shall be able to prevent or activate movement of the elevator equipment.

NOTE (3.5.7): "Equipment" includes all possible moving parts, such as the LCU (car), counterweight, etc.

3.5.8 Uncontrolled, Unintended Equipment Movement Inside the Hoistway

Means shall be provided to protect elevator personnel from the effects related to uncontrolled or unintended movement of equipment inside the hoistway. Any acceleration or deceleration to which elevator personnel are subjected as a result of uncontrolled or unintended movement shall be limited to sufficiently mitigate the risk of harm.

NOTE (3.5.8): If the contact can be harmful, elevator personnel should be provided with means to mitigate such hazards, such as controls over equipment movement or permanently available screens that separate the moving parts from the working area so as to guard against accidental contact. "Equipment" includes all possible moving parts, such as the LCU (car), counterweight, etc.

3.5.9 Means of Protection from Various Hazards

Means shall be provided to adequately protect elevator personnel in working spaces from the effects of shearing, crushing, abrasion, laceration, high temperature, or entrapment.

3.5.10 Falling Objects in the Hoistway

While in the hoistway, elevator personnel shall be adequately protected from falling objects.

NOTE (3.5.10): Objects, e.g., handheld tools, loose material, etc., can fall because of an accidental reaction on the part of a person.

3.5.11 Electric Shock in Working Spaces

Equipment shall be designed and installed to minimize harm to elevator personnel due to the effects of electricity.

NOTE (3.5.11): Elevator service sometimes requires that elevator personnel access live parts of electrical equipment. See also 3.1.9.

3.5.12 Illumination of Working Spaces

All working spaces and access thereto shall be provided with adequate illumination for the use of elevator personnel.

NOTE (3.5.12): Adequate illumination means that the level of light is sufficient for safe access and for performance of any maintenance operation of the elevator equipment. Illumination may be switched off in the absence of elevator personnel.



PART 4

SAFETY PARAMETERS

4.1 Introduction

4.1.1

According to 2.1.2.3, a GESR states only the safety objective, or “what” shall be done or accomplished, but not “how” to accomplish the objective. Therefore, to achieve the safety objective of a GESR, elevator components (such as car safeties activated by governors, buffers, and unintended car movement detection, speed monitoring, door interlock, motion-control system, and electric protective devices) and functions (such as door monitoring, hospital service, and firefighters’ emergency operation) shall be selected and verified for their conformance with the GESR. The capability of selected components and functions to eliminate or sufficiently mitigate risks shall then be demonstrated.

4.1.2

According to 2.9, determination that a risk has been sufficiently mitigated, i.e., that the applicable GESR has been fulfilled, will sometimes require that specific safety parameter values be achieved (such as reliability, strength, durability, clearances, and/or acceleration or retardation values). Requirements for provision of specific components, functions, and safety parameters on an elevator are usually specified in “prescriptive” type standards such as ASME A17.1/CSA B44. This performance-based Code does not mandate the use and implementation of any specific components, functions, or SPs because it would inhibit safe innovative designs and the implementation of new technology.

4.2 Components, Functions, and SPs

4.2.1

No prescriptive requirements for, or examples of, components or functions are stated in this Code. However, examples of safety parameters that could be applicable to the components and functions, such as limits of retardation, tripping speed, kinetic energy, loading, strength, or dimensional limits, are listed in Nonmandatory Appendix Table B-1. The SPs in Nonmandatory Appendix Table B-1 have been extracted from several codes and standards, including ASME A17.1/CSA B44.

4.2.2

The list of SPs in Nonmandatory Appendix Table B-1 is not comprehensive. Listed SPs shall not be interpreted as the only measure of conformity with a GESR. Conformance with a GESR shall be permitted to be achieved by deviating from the listed SPs, provided that the risk is mitigated using other equally effective protective measures. Parameters consistent with good engineering practices or selected from applicable codes or standards shall be permitted. In all cases it is necessary to demonstrate that

- the type of parameters chosen will sufficiently mitigate the risk addressed in the GESR; and
- any new hazard created by implementation of the parameter(s) shall be sufficiently mitigated.

4.2.3

SPs in Nonmandatory Appendix Table B-1 address only safety hazards in related GESRs. The parameters given for a GESR will not necessarily mitigate all hazards relevant to a specific elevator system, sub-system, component, or function. However, those hazards will be addressed in another GESR (see 2.4).

4.2.4

GESRs shall be permitted to be fulfilled by providing EPDs as required by ASME A17.1/CSA B44. If the control system employs PES, SILs as given in Nonmandatory Appendix Table A-1 shall be permitted to be used to fulfill the GESRs.



4.2.5

Nonmandatory Appendix Table B-2 contains a summary of anthropometric data that shall be permitted to be used where specific dimensions are necessary. To mitigate a certain hazard, it is necessary to consider the type of persons (adult or child) or person's body part dimensions (such as body, limb, foot, head, or finger) that shall be protected from a hazard. The data shall also be permitted to be used for establishing clearances necessary to pass through an obstruction or to perform work.

4.3 General

4.3.1

This Code allows the use of designs of components and functions different from those described and specified in ASME A17.1/CSA B44, such as use of car free-fall and car over-speed protective devices that are different from "car safeties and speed-governor assemblies", provided that the installed components and functions meet the GESRs.

4.3.2

According to Part 2, the fundamental measure of safety of an elevator is its full conformance with applicable GESRs. The designers or manufacturers shall demonstrate that selected protective measures, in the form of selected components, functions, and safety parameters, assure full conformance of the elevator with applicable GESRs.



PART 5 REFERENCE CODES AND STANDARDS

This Part covers the codes, standards, and specifications referenced in this Code and the specific editions that are applicable. This Part also lists the names and addresses of the organizations from which these documents can be procured. Only that portion of the code, standard, or specification as specified by the requirements in this Code is applicable.

SECTION 5.1 REFERENCE DOCUMENTS

Designation	Standard	Procurement
16 CFR Part 1201-86	Architectural Glazing Standards and Related Materials	US GPO
ADAAG	Americans with Disabilities Act Accessibility Guidelines	US ATBCB
ANSI/ACI 318-02/R318-02	Building Code Requirements for Structural Concrete and Commentary	ACI
ANSI A10.4 (latest edition)	Safety Requirements for Personnel Hoists	ANSI
ANSI A10.5 (latest edition)	Safety Requirements for Material Hoists	ANSI
ANSI A92 (latest edition)	Mobile Scaffolds, Towers, and Platforms	SIA
ANSI A1264.2 - 2001	Standard for the Provision of Slip Resistance on Walking-Working Surfaces	ANSI
ANSI/Vol. Prod. Std. PS-1-74	Construction and Industrial Plywood	APA
ASCE 7-02	Minimum Design Loads for Building and Other Structures	ASCE
ASME A17.1/CSA B44 (latest edition)	Safety Code for Elevators and Escalators	ASME and CSA
ASME A17.7.1/ CSA B44.7.1 (under development)	General Requirements for Accredited Elevator/Escalator Certification Organizations, Guidance for ISO/IEC Guide 65:1996	ASME and CSA
ASME A18.1 (latest edition)	Safety Standard for Platform Lifts and Stairway Chairlifts	ASME
ASME A90.1 (latest edition)	Safety Standard for Manlifts	ASME
ASME A120.1 (latest edition)	Safety Requirements for Powered Platforms for Building Maintenance	ASME
ASME B20.1 (latest edition)	Safety Standard for Conveyors and Related Equipment	ASME
ASME B30 (latest edition)	Safety Standards for Cableways, Cranes, Derricks, Hoists, Hooks, Jacks and Slings	ASME
ASME B56 (latest edition)	Powered and Nonpowered Industrial Trucks	ASME
ASTM A27/A27M-03	Standard Specification for Steel Castings, Carbon, for General Application	ASTM



Designation	Standard	Procurement
ASTM A36/A36M-04	Standard Specification for Carbon Structural Steel	ASTM
ASTM A283/A283M-03	Standard Specification for Low and Intermediate Tensile Strength Carbon Steel Plates	ASTM
ASTM A307-04	Standard Specification for Carbon Steel Bolts and Studs, 60 000 PSI Tensile Strength	ASTM
ASTM A502-03	Standard Specification for Rivets, Steel, Structural	ASTM
ASTM A668/A668M-04	Standard Specification for Steel Forgings, Carbon and Alloy, for General Industrial Use	ASTM
ASTM E8-04	Standard Test Methods for Tension Testing of Metallic Materials	ASTM
ASTM E84-04	Standard Test Method for Surface Burning Characteristics of Building Materials	ASTM
ASTM E648-03	Standard Test Method for Critical Radiant Flux of Floor Covering Systems using a Radiant Heat Energy Source	ASTM
CAN/CGSB-12.1-M90	Safety Glass, Toughened Glass, Laminates, Doors, Classification Systems, Specifications, Impact Testing, Test Equipment	CGSB
G40.20-04/G40.21-04	General Requirements for Rolled or Welded Structural Quality Steel/Structural Quality Steel	CSA
CAN/CSA-S16-01	Limit States Design of Steel Structures	CSA
A23.3-04	Design of Concrete Structures	CSA
ASME A17.1/CSA B44-07	Safety Code for Elevators and Escalators	ASME and CSA
CAN/CSA-B44.1/ ASME A17.5-04	Elevator and Escalator Electrical Equipment	ASME and CSA
ASME A17.7.1/ CSA B44.7.1 (under development)	General Requirements for Accredited Elevator/Escalator Certification Organizations, Guidance for ISO/IEC Guide 65:1996	ASME and CSA
CAN/CSA-B167-96 (R2002)	Safety Standard for Maintenance and Inspection of Overhead Cranes, Gantry Cranes, Monorails, Hoists and Trolleys	CSA
CAN/CSA-B311-02	Safety Code for Manlifts	CSA
B335-04	Safety Standard for Lift Trucks	CSA
CAN/CSA-B354.1-04	Portable Elevating Work Platforms	CSA
CAN/CSA-B355-00 (R2005)	Lifts for Persons with Physical Disabilities	CSA
CAN/CSA-B613-00 (R2005)	Private Residence Lifts for Persons with Physical Disabilities	CSA
C22.1-06	Canadian Electrical Code, Part I (20th Edition), Safety Standard for Electrical Installations	CSA
CSA C22.2 No. 141-02	Unit Equipment for Emergency Lighting	CSA
O151-04	Canadian Softwood Plywood	CSA



Designation	Standard	Procurement
CAN/CSA-Z150-98 (R2004)	Safety Code on Mobile Cranes	CSA
CAN/CSA-Z185-M87 (R2006)	Safety Code for Personnel Hoists	CSA
CAN/CSA-Z248-04	Code for Tower Cranes	CSA
CAN/CSA-Z256-M87 (R2006)	Safety Code for Material Hoists	CSA
CAN/CSA-Z271-98 (R2004)	Safety Code for Suspended Elevating Platforms	CSA
EN 12016: 1998	Electromagnetic Compatibility-Product Family Standard for Lifts, Escalators and Passenger Conveyors Immunity	ANSI
	Humanscale Manual	MIT Press
ICC/ANSI A117.1-2003	Accessible and Usable Building and Facilities	ICC
IEC 60364-1:2001	Low-voltage electrical installations	ANSI in US SCC in Canada
IEC 61508-5:1998	Functional safety of electrical/electronic/programmable electronic safety-related systems – Part 5: Examples of methods for the determination of safety integrity levels	ANSI in US SCC in Canada
ISO 2860:1992	Earth moving machinery – Minimum access dimensions	ANSI in US SCC in Canada
ISO 7250:1996	Basic human body measurements for technological design	ANSI in US SCC in Canada
ISO 11228-1:2003	Ergonomics – Manual Handling – Part 1: Lifting and Carrying	ANSI in US SCC in Canada
ISO 13852:1996	Safety of machinery. Safety distances to prevent danger zones being reached by the upper limits (EN 284)	ANSI in US SCC in Canada
ISO 13854:1996	Safety of machinery. Minimum gaps to avoid crushing of parts of the human body (EN 349)	ANSI in US SCC in Canada
ISO 14121:1999	Safety of machinery – Principles of risk assessment	ANSI in US SCC in Canada
ISO 14798: 2005	Lifts, escalators and moving walks – Risk assessment and risk reduction methodology	ANSI in US SCC in Canada
ISO 15534-1:2000	Ergonomic design for the safety of machinery – Part 1: Principles for determining the dimensions required for opening for whole-body access into machinery	ANSI in US SCC in Canada
ISO 15534-2:2000	Ergonomic design for the safety of machinery – Part 2: Principles for determining the dimensions required for access openings	ANSI in US SCC in Canada
ISO 15534-3:2000	Ergonomic design for the safety of machinery – Part 3: Anthropometric data	ANSI in US SCC in Canada
ISO 3411:1995	Earth moving machinery – Human physical dimensions of operators and minimum operating space	ANSI in US SCC in Canada



Designation	Standard	Procurement
ISO/IEC Guide 51:1999	Safety aspects – Guidelines for their inclusion in standards	ANSI in US SCC in Canada
ISO/IEC 17000:2004	Conformity assessment – Vocabulary and general principles	ANSI in US SCC in Canada
ISO/TS 22559-1:2004	Safety requirements for lifts (elevators) – Part 1 – Global essential safety requirements (GESRs) for lifts (elevators)	ANSI in US SCC in Canada
NFPA 70 - 2005	National Electrical Code	NFPA
NFPA 255 - 2000	Surface Burning Characteristics of Building Materials	NFPA
AS/NZS 4586-2004	Slip resistance classification of new pedestrian surface materials	AS//NZS
UL 723-2003	Surface Burning Characteristics of Building Materials	UL
US Army	1988 Anthropometric Survey of U.S. Army Personnel	US GPO
US MIL STD-882C	System Safety Program Requirements	US GPO
ZHA-Guide (1987)	Zurich Hazard Analysis: A brief introduction to the Zurich method of hazard analysis	ZSC



SECTION 5.2 PROCUREMENT INFORMATION

Organization	Address and Telephone Number	Organization	Address and Telephone Number
ACI	American Concrete Institute 38800 Country Club Drive Farmington Hills, Michigan 48331, USA Telephone: (248) 848-3700 Fax: (248) 848-3701 http://www.aci-int.org	CGSB	Canadian General Standards Board Gatineau, Québec, Canada K1A 1G6 Telephone: (819) 956-0425 Fax: (819) 956-5644 http://www.pwgsc.gc.ca/cgsb/
ANSI	American National Standards Institute, Inc. 25 West 43rd Street New York, New York 10036, USA Telephone: (212) 642-4900 http://www.ansi.org	CSA	CSA Sales Department 5060 Spectrum Way, Suite 100 Mississauga, Ontario, Canada L4W 5N6 Telephone: (800) 463-6727 http://www.csa.ca
APA	American Plywood Association P.O. Box 11700 Tacoma, Washington, USA 98411-0700 Telephone: (253) 565-6600 http://www.apawood.org	ICC	International Code Council 5203 Leesburg Pike Suite 600 Falls Church, Virginia 22041, USA Telephone: (703) 931-4533 http://www.iccsafe.org
ASCE	American Society of Civil Engineers 1801 Alexander Bell Drive Reston, Virginia 20191-4400, USA Telephone: (800) 548-2723 Fax: (703) 295-6222 http://www.asce.org	MIT Press	The MIT Press Bookstore 292 Main Street Cambridge, Massachusetts 02142, USA Telephone: (617) 253-5249 Fax: (617) 258-6894 http://mitpress.mit.edu/bookstore
ASME	The American Society of Mechanical Engineers Three Park Avenue New York, New York 10016, USA Telephone: (212) 591-8500 http://www.asme.org ASME Order Department 22 Law Drive Box 2300 Fairfield, New Jersey 07007-2300, USA Telephone: (201) 882-1167 (800) 843-2763	NFPA	National Fire Protection Association 1 Batterymarch Park P.O. Box 9101 Quincy, Massachusetts 02269-9101, USA Telephone: (617) 770-3000 http://www.nfpa.org
ASTM	American Society for Testing and Materials 100 Barr Harbor Drive W. Conshohocken, Pennsylvania 19428-2959, USA Telephone: (610) 832-9500 http://www.astm.org	SCC	Standards Council of Canada 270 Albert Street, Suite 200 Ottawa, Ontario, Canada K1P 6N7 Telephone: (613) 238-3222 Fax: (613) 569-7808 http://www.scc.ca
AS/NZS	Excel Partnership, Inc. 75 Glen Road Sandy Hook, Connecticut 06482, USA Telephone: (800) 374-3818 http://www.xlp.com/	SIA	Scaffold Industry Association, Inc. 20335 Ventura Blvd., Suite 310 Woodland Hills, California 91364, USA Telephone: (818) 610-0320 http://www.scaffold.org
		UL	Underwriters Laboratories, Inc. 333 Pfingsten Road Northbrook, Illinois 60062, USA Telephone: (847) 272-8800 http://www.ul.com



Organization	Address and Telephone Number	Organization	Address and Telephone Number
ULC	Underwriters' Laboratories of Canada 7 Underwriters Road Toronto, Ontario, Canada M1R 3B4 Telephone: (416) 757-3611 Fax: (416) 757-8727 http://www.ulc.ca	US GPO	U.S. Government Printing Office Superintendent of Documents Washington, DC 20402, USA Telephone: (202) 512-1800 (866) 512-1800 http://www.gpo.gov
US ATBCB	United States Architectural and Transportation Barriers Compliance Board 131 F Street, NW, Suite 1000 Washington, DC 20004-1111, USA Telephone: (202) 272-0020 http://www.access-board.gov	ZSC	Zurich Service Corporation Telephone: (800) 695-6036 http://www.zurichservices.com/



MANDATORY APPENDIX I

CERTIFICATION OF CONFORMANCE OF ELEVATOR SYSTEMS, SUB-SYSTEMS, COMPONENTS, OR FUNCTIONS

I-1 General

An applicant or authorized representative shall obtain a Certificate of Conformance to ASME A17.7/CSA B44.7 for sub-systems, components, or functions (see Mandatory Appendix I-3) or elevator system (see Mandatory Appendix I-4), whichever is applicable.

I-2 Model Elevator

I-2.1

Where an elevator system is designated as a Model Elevator by the manufacturer, the applicant shall be required to obtain a Certificate of Conformance for the initial representative model only. Subsequent series-produced elevators with the same design and configuration as the model representative shall not be required to be submitted for certification.

I-2.2

All permitted variations between the model elevator and the installed elevators shall be clearly specified (with minimum and maximum values, features, etc.) in the technical documentation (see Mandatory Appendix I-4.3).

I-2.3

By calculation and/or on the basis of design plans, it shall be permitted to demonstrate the similarity of a range of equipment to satisfy the GESRs.

I-3 Certification of Sub-Systems, Components, or Functions

I-3.1

Certification of sub-systems, components, or functions is the procedure whereby an AECO certifies that a representative sample of a sub-system, component, or function of an elevator system will permit the elevator system to satisfy the relevant requirements of 2.2.1(b) or (c), provided the sub-system, component, or function is correctly fitted to the elevator system as specified in the manufacturer's CCD.

I-3.2

The application for certification of sub-systems, components, or functions shall be submitted by the applicant or an authorized representative to an AECO. The application shall include the following:

- (a) the name and address of applicant;
- (b) the name and address of the manufacturer of the sub-system, component, or function or the authorized representative and the place of manufacture of the sub-system, component, or function;
- (c) a written declaration that the same application has not been submitted to any other AECO, or a written explanation as to why the application is being submitted to another AECO;
- (d) technical documentation (see Mandatory Appendix I-3.3); and
- (e) a representative sample(s) of the sub-system, component, or function, or details of the place where it can be examined.

I-3.3

Technical documentation shall be provided for an AECO to assess the conformity of a sub-system, component, or function when it is correctly fitted as specified in the manufacturer's CCD (see I-3.1).



The technical documentation shall include the following:

- (a) CCD (see 2.10);
- (b) a general description of the sub-system, component, or function, including its intended use (possible limitations such as speed, load, power, etc.) and conditions affecting use (such as explosive environments, exposure to the elements, etc.);
- (c) design and manufacturing drawings or diagrams;
- (d) GESRs taken into consideration and the means adopted to conform;
- (e) results of all applicable tests or calculations performed or subcontracted by the applicant or manufacturer;
- (f) a copy of the assembly instructions for the sub-system, component, or function; and
- (g) steps taken at the manufacturing stage to ensure that the series-produced sub-system, component, or functions conform to the sub-system, component, or function examined.

I-3.4

The AECO shall

- (a) examine the technical documentation to verify that the sub-system, component, or function meets the relevant GESRs; and
- (b) perform or have performed appropriate checks and tests necessary to determine whether the solutions adopted by the manufacturer of the sub-system, component, or function meet the requirements of this Code, allowing the sub-system, component, or function to carry out its function when correctly fitted on an elevator as specified in the manufacturer's CCD.

I-3.5

I-3.5.1

When the AECO confirms that the representative sub-system, component, or function conforms to the applicable requirements of this Code, the AECO shall issue a Certificate of Conformance to the applicant.

I-3.5.2

The certificate and accompanying documents, if any, shall include the following:

- (a) the name and address of the manufacturer of the sub-system, component, or function and the name and address of the applicant, if other than the manufacturer;
- (b) the scope of the certification, including, as appropriate:
 - (1) product(s) certified, which shall be permitted to be identified by type or range of products;
 - (2) relevant parts of this Code (such as GESRs, SPs, etc.) to which each product or product type is certified; and
 - (3) statement of compliance with ASME A17.7/CSA B44.7; and
- (c) the effective date of the certificate and the term (time limit), if applicable.

I-3.5.3

If the AECO refuses to issue a Certificate of Conformance to the applicant, it shall state the detailed grounds for refusal.

NOTE (I-3.5.3): Provision for appeal of an AECO's decision is one of the requirements for accreditation of AECOs.

I-3.6

The applicant who has received a Certificate of Conformance for a sub-system, component, or function shall inform the AECO in writing of any modifications to the sub-system, component, or function that could affect the safety of the system in which it is applied. The AECO is required to examine the modifications and inform the applicant whether the Certificate of Conformance remains valid. Changes in the design that do not affect the safety of the system shall be permitted to be made without the approval of the AECO.



I-4 Certification of Elevator Systems

I-4.1

Certification of an elevator system is the procedure whereby an AECO certifies that an elevator system satisfies the requirements of 2.2.1(b) or (c).

I-4.2

The application for certification of an elevator system shall be submitted by the applicant or an authorized representative to an AECO.

The application shall include the following:

- (a) the name and address of the applicant or the authorized representative and the place of manufacture of the elevator system;
- (b) a written declaration that the same application has not been submitted to any other AECO, or a written explanation as to why the application is being submitted to another AECO;
- (c) technical documentation (see Mandatory Appendix I-4.3); and
- (d) details of the location where the elevator system can be examined. The elevator system submitted for examination and certification shall include all parts and be capable of serving at least three levels (top, middle and bottom) unless the system is specifically limited in scope to a two-stop application.

I-4.3

The technical documentation shall provide sufficient understanding of the design and operation of the elevator system to facilitate verification of its conformity to the requirements of this Code.

The technical documentation shall include the following:

- (a) CCD (see 2.10);
- (b) a general description of the elevator system under examination, indicating all possible extensions to it (see also definition of "model elevator");
- (c) design and manufacturing drawings or diagrams;
- (d) GESRs taken into consideration and means adopted to satisfy them;
- (e) results of any tests or calculations performed or subcontracted by the manufacturer, applicant, or installer; and
- (f) steps taken at the installation stage to ensure that the elevator system conforms to the requirements of this Code.

I-4.4

The AECO shall:

- (a) examine the technical documentation to verify that the elevator system meets the relevant GESRs; and
- (b) perform or have performed the appropriate checks and tests necessary to determine that the elevator system meets the requirements of this Code.

I-4.5

I-4.5.1

When the AECO confirms that the elevator system complies with the applicable requirements of this Code, the AECO is required to issue a Certificate of Conformance to the applicant.



I-4.5.2

The certificate and related documents shall include the following:

- (a) the name and address of the supplier whose products are the subject of certification.
- (b) the scope of the certification, including, as appropriate:
 - (1) products certified, which shall be permitted to be identified by type or range of products;
 - (2) relevant parts of this Code to which each product or product type is certified;
 - (3) statement of compliance with ASME A17.7/CSA B44.7; and
- (c) the effective date of the certificate and the term (time limit) if applicable.

I-4.5.3

If the AECO refuses to issue a Certificate of Conformance to the applicant, it shall state the detailed grounds for refusal.

NOTE (I-4.5.3): Provision for appeal of an AECO's decision is one of the requirements for accreditation of AECOs.

I-4.6

The applicant who has received a Certificate of Conformance for an elevator system shall inform the AECO in writing of any modifications that could affect the safety of the system. The AECO shall examine the modifications and inform the applicant whether the Certificate of Conformance remains valid.

Changes in the design that do not affect the safety of the system shall be permitted to be made without the approval of the AECO.

I-5 AECO Records

Each AECO shall maintain up-to-date records, available in a publicly accessible medium, containing the relevant information concerning

- (a) Certificates of Conformance issued; and
- (b) Certificates of Conformance withdrawn.

I-6 Marking of Sub-Systems and Components

The elevator sub-system or component shall be labeled, marked, or tagged with the following data:

- (a) the name or trademark of the manufacturer, or AECO Certificate of Conformance identification by which the organization that manufactured the device can be identified;
- (b) the AECO mark, name, or identifying symbol, if applicable;
- (c) the AECO Certificate of Conformance identification, if applicable;
- (d) statement of compliance with ASME A17.7/CSA B44.7;
- (e) a distinctive type, model, or style letter or number; and
- (f) any conditions of validity of the certificate and any particulars necessary to identify the type of component certified, as determined by the AECO.

NOTE (I-6): Sub-systems and components that require inspection and testing should have informational data provided in the MCP, such as application forces, speeds, strengths, voltages, currents, etc.



NONMANDATORY APPENDIX A BACKGROUND TO GESRs

NONMANDATORY APPENDIX A-1 APPROACH AND GESR DEVELOPMENT METHODOLOGY

A-1.1 Approach

A-1.1.1

The GESRs in this Code, and the method of applying them, are consistent with the GESRs and approach of ISO/TS 22559-1, which was developed following ISO/IEC Guide 51. Minor modifications have been made in this Code to the GESRs and the methodology of ISO/TS 22559-1 to use terminology consistent with North American practice and to cover the scope of this Code.

A-1.1.2

The intent of ISO/TS 22559-1 was to develop essential safety requirements (ESRs) for elevators, whereby the elevator is defined in broad terms as a “unit” carrying load from one floor to another, without any design constraints such as those that are usually specified in regional or national elevator standards. Consequently, a load-carrying unit [LCU (car)] of an elevator in this document is not necessarily a “car” that consists of a platform with fully enclosed sides and ceiling. The space in which the unit travels is not necessarily a fully enclosed “hoistway” as this term is defined in national standards.

A-1.1.3

By taking this approach and by using a systematic risk assessment process in accordance with ISO 14798, it was possible to establish essential safety requirements (ESRs) for elevators without imposing restrictions on the design or materials and technologies used.

A-1.2 Development of ISO/TS 22559-1

A-1.2.1

In order to involve experts from various parts of the world, three regional study groups were formed (North American, European, and Asia-Pacific) with broad participation of regional elevator experts.

A-1.2.2

Following the risk assessment methodology specified in ISO 14798, each study group

- (a) identified safety risk scenarios, including hazardous situations and harmful events (causes and effects) that could arise from the maintenance, operation, inspection, testing, and use of elevators;
- (b) estimated and evaluated the risk; and
- (c) formulated ESRs when the risks required mitigation.

NOTE (A-1.2.2): Table A-1 gives several examples of risk scenarios related to several GESRs.

A-1.2.3

Reports on the analysis of risk scenarios and essential safety requirements proposed by each study group were compared and debated within ISO/TC 178 Working Group 4 before the final proposals for global essential safety requirements (GESRs) for elevators, reproduced in Part 3 of this Code, were established. The GESRs thus established represent a substantial international consensus.

Table A-1
Examples of risk scenarios related to GESRs

Risk scenarios	Applicable GESR # (see Part 3)
<p>EXAMPLE 1</p> <p>1.1 Users are on a moving LCU (car) that has low or perforated guards on its sides; a user extends a hand or protrudes a foot beyond the LCU (car) perimeters; the hand or foot engages with external elevator objects and is sheared, crushed, or cut.</p> <p>1.2 Users are in the elevator entrance area prepared to enter the LCU (car); the entrance door is moving; the doors move towards, and contact, the users who are entering the LCU (car); people are crushed or sheared or they are destabilized, possibly resulting in an injury due to a fall.</p> <p>1.3 Non-users are at the floor area in the vicinity of the elevator entrance or at the floor around the LCU (car) travel path; the enclosure around the LCU (car) travel path is low in height or perforated; a person extends a hand or protrudes a foot towards the moving LCU (car) or any other moving elevator equipment in the travel path, which engages with the hand or foot; then the hand or foot is sheared, crushed, or cut.</p>	<p>3.1.5. Hazards Due to Relative Movement</p> <p>Users and non-users shall be protected from the effects of shearing, crushing, or abrasion or other injuries due to</p> <p>(a) relative movement of the LCU (car) and external objects; and</p> <p>(b) relative movement of the elevator equipment.</p>
<p>EXAMPLE 2</p> <p>2.1 There are no guards between the LCU (car) travel path and the floors surrounding the travel path. If a person leans over the floor edge or the entrance opening sill, the person can fall down the hoistway.</p> <p>2.2 If guards are provided but have no adequate strength, a person could lean against a guard, break through it, and fall down into the hoistway.</p>	<p>3.2 GESRs RELATED TO PERSONS ADJACENT TO THE ELEVATOR — FALLING INTO HOISTWAYS</p> <p>Means shall be provided to prevent the risk to users, non-users, and elevator personnel falling into the hoistway.</p>
<p>EXAMPLE 3</p> <p>Users or non-users have access to elevator machinery and/or the equipment installed to move or control the LCU (car); these persons could then inadvertently or deliberately come in contact with moving or rotating machinery or electrical equipment; this could result in serious injury if the person is drawn into or comes into contact with the machinery; a person could be electrocuted if he or she comes into contact with exposed electrical equipment.</p>	<p>3.1.3 Equipment Inaccessible to Users and Non-Users</p> <p>Equipment that is hazardous shall not be directly accessible to users and non-users.</p>
<p>EXAMPLE 4</p> <p>Elevator personnel are working on top of the LCU (car) or in some other working space that does not have sufficient strength to support the personnel and tools; the working surface collapses and the personnel fall into the LCU (car), seriously injuring themselves and anybody inside the LCU (car).</p>	<p>3.5.4 Strength of Working Areas</p> <p>Means shall be provided to accommodate and support the weight of elevator personnel and associated equipment in any designated working area.</p>



NONMANDATORY APPENDIX A-2 UNDERSTANDING AND IMPLEMENTING GESRs

A-2.1 Overall Objective

A-2.1.1

Compliance with ASME A17.7/CSA B44.7 is an effective method of providing safety on elevators.

A-2.1.2

Part 3 contains objectives for elevators in the form of global essential safety requirements (GESRs) to be taken into consideration when mitigating safety risks that elevators can present.

A-2.1.3

The objective of GESRs in Part 3 is to

- (a) introduce a universal approach to identifying and mitigating potential safety risks on new elevator system, sub-system, component, or function designs employing new technologies, materials, or concepts not adequately addressed in existing standards; and
- (b) stimulate harmonization of existing elevator safety standards.

A-2.1.4

Given the present state of the art, objectives specified by GESRs are sometimes not fully attainable. In such cases the elevator system, sub-system, component, or function must be designed and built to satisfy those objectives to the greatest possible extent.

A-2.1.5

A GESR states only the safety objective, or “what” must be done or accomplished, but not “how” to accomplish the objective. Therefore, to achieve the safety objective of a GESR, appropriate designs of elevator systems, sub-systems, components, or functions must be selected and compliance with the GESR verified. In other words, the ability of the selected elevator system, sub-system, component, or function to eliminate or sufficiently mitigate safety risks must be demonstrated.

A-2.2 Use of GESRs

A-2.2.1 Basis

Each GESR specified in Part 3 was established after performing a risk assessment of one or more risk scenarios that can result in harm to persons (see Nonmandatory Appendix Table A-1). Consequently, when assessing the safety of an elevator system, sub-system, component, or function, risk scenarios are to be analyzed and applicable GESRs identified.

NOTE (A-2.2.1): Risk assessment is carried out in accordance with ISO 14798.

A-2.2.2 Ways of Using GESRs

A-2.2.2.1

GESRs can be used in two ways:

- (a) risk analysis of risk scenarios related to the task in order to identify the applicable GESRs as in A-2.2.2.2; or
- (b) a review of all GESRs in order to identify those that could be applicable to the task, as in A-2.2.2.3

NOTE (A-2.2.2.1): In addition to designing, tasks could include installing or servicing of elevator systems, sub-systems, components, or functions thereof.

A-2.2.2.2

When designing an elevator system, sub-system, component, or function, a review of the design is made, in which risk scenarios are formulated and risk assessments are performed in order to find out which, if any, GESRs are applicable to the design. One should consider risk scenarios that could occur during operation and use, as well as during the maintenance or inspection of the elevator.

The risk scenarios should include specification of hazardous situations, combined with causes and effects, including possible degrees of harm. The risk analysis of a scenario is followed by the process of risk estimation and evaluation in accordance with the methodology specified in ISO 14798. As long as a risk is assessed as not acceptable, the designer is required to continue to improve the design or is required to implement other protective measures until the applicable GESR has been fully complied with.

EXAMPLE (A-2.2.2.2): *By following this process, risk scenarios similar to those in Example 1 in Nonmandatory Appendix Table A-1 could be formulated, and it could be concluded that there is a possibility of injury to persons exposed to shearing, crushing, or abrasion hazards. The assessment of the risk will indicate that the risk needs further mitigation, which can be achieved by changing the design or by implementing other protective measures, in order to comply with GESR 3.1.5.*

NOTES (A-2.2.2.2):

- (1) For practical use of GESRs, see A-2.3.
- (2) Rationale for GESRs are given in NOTES following each GESR in Part 3. They should assist understanding of the intent and use of GESRs.

A-2.2.2.3

The process starts with a review of GESRs specified in Part 3. In this case, design or actual installation of elevator systems, sub-systems, components, or functions is considered, with the intent of identifying GESRs applicable to design, installation, or components. Compliance with each identified GESR must be assessed. If compliance is not self-evident, risk assessment must be completed to demonstrate compliance.

EXAMPLE (A-2.2.2.3): *In the case of GESR 3.1.5 in Example 1 in Nonmandatory Appendix Table A-1, the elevator design or installation is examined to find out whether any person traveling in the LCU (car), entering or exiting the LCU (car), being around the elevator travel path or hoistway, or being in any similar situation could be exposed to shearing, crushing, abrasion, or a similar hazard that can cause harm.*

A-2.2.3 Applicability of GESRs

When analyzing the safety of an elevator system, sub-system, component, or function, the applicability of all relevant GESRs should be determined. Systematic descriptions of risk scenarios, combined with risk assessment, would help to determine applicability of individual GESRs.

NOTE (A-2.2.3): *GESR 3.1.12, related to effects of earthquake on elevators, and GESR 3.4.13, related to the risk of an LCU (car) being affected by flood, are examples of GESRs that are not applicable to every elevator.*

A-2.2.4 GESRs as Safety Objectives

A-2.2.4.1

GESRs are not “protective measures” as defined in ISO 14798. A GESR states only the safety objective; it does not specify how the objective is to be achieved. Therefore, when an elevator is being designed, appropriate components and functions in terms of size, dimensions, strength, force, energy, material, acceleration, reliability of performance of safety-related parts, etc., must be selected as applicable, and their ability to eliminate or sufficiently mitigate risks to achieve compliance with the objective specified by the GESR must be established.

NOTE (A-2.2.4.1): *There are additional GESRs applicable to the guards on the LCU (car) sides (see 3.4.4) and the LCU (car) travel path or hoistway sides (see Example 2 in Nonmandatory Appendix Table A-1); they are related to the risk of persons falling into the travel path from the LCU (car) and from the floors around the travel path.*



EXAMPLE (A-2.2.4.1):

In the case of Example 1 in Nonmandatory Appendix Table A-1, in order to eliminate or mitigate the risks to persons inside the LCU (car), in the elevator entrance area, and in the area around the LCU (car) travel path, the following must be determined:

- (a) *the minimum height of the guards or walls on the sides of the LCU (car) platform;*
- (b) *the maximum size of perforations (openings) in the LCU (car) guards or walls, if any;*
- (c) *the maximum permissible impact, force, speed, and kinetic energy, if any, of the door when closing on the person;*
- (d) *the minimum height of the guards or wall separating the LCU (car) travel path and other moving components from the elevator landing and floor area around the elevator; and*
- (e) *the maximum perforation (openings) in the guards or walls around the travel path, if any.*

A-2.2.4.2

To assess the risk presented by an elevator system, sub-system, component, or function, the elevator should be divided into sub-systems, and risk scenarios assessed one sub-system at a time. However, one GESR can be applicable to more than one sub-system (see Nonmandatory Appendix Table A-3).

A-2.2.5 Verification of Conformance

To establish the ability of a selected elevator system, sub-system, component, or function to eliminate or sufficiently mitigate a risk, as required in A-2.2.4, risk analysis will be carried out.

A component can be assessed as being able to eliminate or sufficiently mitigate a risk, but the same component can create a new hazard or the component can incorporate elements that could fail and void the protective function of the whole system. For that reason, reliability of components, built-in elements, and functions to perform as intended must be established through a risk assessment process.

EXAMPLE (A-2.2.5): *A failure of a single solid-state or software element in the LCU (car) speed-control components, which are provided for compliance with GESR 3.4.6, can make the component non-functional, allowing the LCU (car) to move out of control.*

A-2.3 Use of this Code

A-2.3.1 Users

This Code provides a uniform process for assessing safety of elevators. Global essential safety requirements (GESRs) are intended for use by the following:

- (a) elevator designers, manufacturers and installers, and maintenance and service organizations;
- (b) AECOs; and
- (c) AHJs.

A-2.3.2 Designers, Manufacturers and Installers, and Maintenance and Service Organizations

A-2.3.2.1 Elevator Components and Functions

Elevator components and functions should be designed, manufactured, installed, adjusted, and maintained

- (a) in accordance with the ASME A17.1/CSA B44 Code or locally adopted elevator standards or other applicable standards intended to meet the protection level required by GESRs;
- (b) in accordance with this Code, in which case selected components and functions should be shown to meet the safety objective of GESRs through a risk assessment process, such as ISO 14798; or
- (c) in accordance with a combination of (a) and (b) and, if necessary, should be tested, certified, and assessed for conformity with applicable regional or local regulations.



A-2.3.2.2 Proof of Conformance

A-2.3.2.2.1

Conformance with A-2.3.2.1(a) is achieved by meeting requirements of a standard that is consistent with the GESRs and other regulations applicable to the jurisdiction in which the elevator is to be operated, such as local fire standards, building standards, etc.

A-2.3.2.2.2

Conformance with A-2.3.2.1(b) is achieved by identifying risk scenarios (see A-1.2.2) related to a particular elevator design and by conducting a risk assessment, in order to demonstrate that the requirements specified in applicable GESRs have been complied with, and their safety objectives achieved.

NOTE (A-2.3.2.2.2): According to ISO 14798, a balanced team of experts who have experience in the design, manufacture, installation, maintenance, and inspection of elevators should conduct the risk assessment. The team should be led by a facilitator who is well versed and experienced in elevator technology and in the use of ISO 14798. The results of the study should be documented. Any identified risks should be sufficiently mitigated. This approach is particularly useful for innovative products that have not been covered by existing design-prescriptive standards.

A-2.3.2.2.3

The approach in A-2.3.2.1(c) applies to elevators that meet most requirements of a standard consistent with GESRs, but that have certain innovative features not specifically covered by the standard. Such cases may be handled as follows:

- (a) Identify areas where the elevator does not comply with specific prescriptive requirements of the standard.
- (b) Identify specific requirements of the standard that innovative features do not meet. In addition, identify GESRs related to the requirements that the elevator, in combination with innovative features, cannot meet.
- (c) Conduct a risk assessment, as described in 2.7, of aspects, areas, or features of the elevator that are required to meet GESRs identified in (b). Any identified risk should be sufficiently mitigated.

A-2.3.3 Accredited Elevator/Escalator Certification Organizations (AECOs)

When an AECO is involved in the assessment of conformance of an elevator or its components with GESRs, this document can be used in various ways, including:

- (a) verification of the designer's, manufacturer's, or other organization's documentation (such as designs, testing procedures, reports on risk assessments, etc.) that demonstrates conformity with GESRs; and
- (b) formulating the AECO's risk scenarios and verifying applicability to, and compliance with, specific GESRs.

For this purpose, procedures similar to that described in A-2.2 and A-2.3.2 should be followed.

A-2.3.4 AHJs

Inspectors can use this Code to

- (a) verify that applicable GESRs have been taken into account by the designer, manufacturer, installer, or maintainer;
- (b) verify suitability of proposed inspection and testing procedures in the applicable standard or CCD (2.1.2.3); and
- (c) assess inspection and test results.

For this purpose, a procedure similar to that described in A-2.2 and A-2.3.2 should be followed.



NONMANDATORY APPENDIX A-3 OVERVIEW OF GESRs IN RELATION TO ELEVATOR SUB-SYSTEMS

A-3.1 General

GESRs are specified in Part 3 and are grouped according to the location where a person can be exposed to a hazard or a hazardous situation or event. Table A-3 is provided to assist users who view an elevator as a combination of clearly distinguishable sub-systems. Table A-3 gives an overview of all Part 3 GESRs (except for notes following specific GESRs) in relation to elevator sub-systems.

A-3.2 References and Symbols in Table A-3

A-3.2.1 Symbols in the Table Heading Identifying Sub-Systems

- B** – Building, including its structure, hoistway, machinery space, and building equipment not provided by elevator contractor.
- C** – Control sub-system, including electrical equipment and wiring, except “Sf” (safety devices).
- E** – Landing and LCU (car) entrances.
- G** – Guiding of the LCU (car) and counterweight system.
- H** – Hoistway, including interior and surrounding guards or enclosures.
- L** – Load-carrying unit [LCU (car)], including its top, if applicable.
- M** – Machine, including braking system.
- Sf** – Safety devices.
- Sp** – Suspension of LCU (car) system.
- W** – Working area or space.

A-3.2.2 Symbols in the Table Columns

- X** – A GESR that is primarily applicable to the elevator sub-system(s) identified in the heading.
- O** – A GESR that can be applicable to the elevator sub-system(s) identified in the heading.
- GESR #** – Cross-reference to Part 3 in this Code.
- *** – The GESR for an equivalent hazard is given in 3.5.



Table A-3
Cross-Referencing of GESRs in Part 3 and Elevator Sub-Systems

GESR # Global essential safety requirement in Part 3	Elevator Sub-System [see A-3.2 for symbols]									
	B	C	E	G	H	L	M	Sf	Sp	W
3.1 COMMON GESRs RELATED TO PERSONS AT DIFFERENT LOCATIONS										
3.1.1 Supports for Elevator Equipment The means used to support the elevator equipment shall be capable of sustaining all loads and forces (including impact forces) imposed during normal and emergency operations.	X			O	O				O	O
3.1.2 Elevator Maintenance Where maintenance is required to ensure continued safety, appropriate instructions shall be provided, and elevator personnel shall perform any required work.	O	O	O	O	O	O	O	O	O	O
3.1.3 Equipment Inaccessible to Users and Non-Users Equipment that is hazardous shall not be directly accessible to users and non-users.	O	O	O		X	O	O	O		O
3.1.4 Floors of the LCU (Car) and Working Areas The floors of the LCU (car) and standing areas of workplaces shall minimize the risk of tripping and slipping.						X				X
3.1.5 Hazards Due to Relative Movement Users and non-users shall be protected from the effects of shearing, crushing or abrasion, or other injuries due to (a) relative movement of the LCU (car) and external objects; and (b) relative movement of the elevator equipment.		O	X	O	X	X				
3.1.6 Locking Landing Doors and Closing LCU (Car) Doors Any movement of the LCU (car) that is hazardous to persons shall be stopped if any hoistway door is open or unlocked or the LCU (car) door is not closed.		O	O			O	O	X		
3.1.7 Evacuation Means and procedures shall be provided to enable trapped users or elevator personnel to be safely released and evacuated.	O	O	X		O	X	O	O		X
3.1.8 Sharp Edges Means shall be provided to sufficiently mitigate the risk to users and non-users of exposure to sharp edges.			X		O	X				
3.1.9 Hazards Arising from the Risk of Electrical Shock Where electricity is provided, means shall be provided to sufficiently mitigate the risk to users and non-users of exposure to electrical shock and related hazards.		X	O			O		O		
3.1.10 Electromagnetic Compatibility The safe operation of an elevator shall not be influenced by electromagnetic interferences.		X						O		O
3.1.11 Illumination of LCU (Car) and Landings LCU (car) and landings shall be provided with adequate illumination during use.	O		X			X				

(Continued)

Table A-3
Cross-Referencing of GESRs in Part 3 and Elevator Sub-Systems

GESR #	Global essential safety requirement in Part 3	Elevator Sub-System [see A-3.2 for symbols]									
		B	C	E	G	H	L	M	Sf	Sp	W
3.1.12	Effects of Earthquake In areas subject to earthquake, means shall be provided to minimize the risk to users of the LCU (car) and elevator personnel of the foreseeable effects of earthquakes on the elevator equipment.	O	X		O	O	X	O	O	O	X
3.1.13	Hazardous Materials The characteristics and quantity of material used for the manufacture and construction of the elevator shall not lead to hazardous situations.	O		O		X	X				X
3.1.14	Environmental Influences Users and elevator personnel shall be protected from environmental influences.	O	O			O	X		O		X
3.2 GESRs RELATED TO PERSONS ADJACENT TO THE ELEVATOR — FALLING INTO HOISTWAY											
3.2	Means shall be provided to prevent the risk of users, non-users, and elevator personnel falling into the hoistway.	O		X		X			O		X
3.3 GESRs RELATED TO PERSONS AT THE ELEVATOR ENTRANCES											
3.3.1	Access and Egress Safe means of access and egress shall be provided to the LCU (car) at landings.	O	O	X			X		O		
3.3.2	Horizontal Sill-to-Sill Gap The horizontal gap between the sill of the LCU (car) and that of the landings shall be limited.			X	O		X				
3.3.3	Alignment of LCU (Car) and Landings When users enter or exit the LCU (car), its platform and landing floor shall be substantially aligned.		X	O			O	O			
3.3.4	Self-Evacuation from an LCU (Car) Self-evacuation of users shall be possible only when the LCU (car) is at or near a landing.		X	O		O	X		O		
3.3.5	Gap between the Landing Doors and LCU (Car) Doors The space between the landing doors and LCU (car) doors shall not allow the presence of users.			X			X				
3.3.6	Means to Reopen Doors when LCU (Car) is at Landing Means shall be provided to reopen the LCU (car) and landing doors if their closing is obstructed when the LCU (car) is at the landing.		X	O			O		X		

(Continued)

Table A-3
Cross-Referencing of GESRs in Part 3 and Elevator Sub-Systems

GESR # Global essential safety requirement in Part 3	Elevator Sub-System [see A-3.2 for symbols]									
	B	C	E	G	H	L	M	Sf	Sp	W
3.4 GESRs RELATED TO PERSONS IN THE LCU (CAR)										
3.4.1 Strength and Size The LCU (car) shall accommodate and support the rated load and a reasonably foreseeable overload.				O		X			O	
3.4.2 LCU (Car) Support/Suspension Means shall be provided to support the fully loaded LCU (car) and a reasonably foreseeable overload.				O		X		O	O	X
3.4.3 Overloaded LCU (Car) Means shall be provided to prevent an overloaded LCU (car) from attempting to leave a landing.	X					X		O	O	
3.4.4 Falling from an LCU (Car) Means shall be provided to prevent users from falling from the LCU (car).						X				
3.4.5 LCU (Car) Travel Path Limits The vertical travel of the LCU (car) shall be limited to prevent the LCU (car) from uncontrolled running beyond the travel path.	X		X			O	O	X	O	
3.4.6 Uncontrolled, Unintended Movement of an LCU (Car) Means shall be provided to limit uncontrolled or unintended movement of the LCU (car).	X	O				O	X	X		
3.4.7 LCU (Car) Collision with Objects in or beyond Travel Path Means shall be provided to avoid collision of the LCU (car) with any equipment in the travel path that could cause injuries to users.		O		O	O	X		X	O	
3.4.8 LCU (Car) Horizontal and Rotational Motion Horizontal or rotational motion of the LCU (car) shall be limited to sufficiently mitigate the risk of injury to users and elevator personnel.	O	O		X	O	X				O
3.4.9 Change of Speed or Acceleration Means shall be provided to ensure that any change of speed or acceleration of the LCU (car) shall be limited to minimize the risk of injury to the users.	X							O	X	
3.4.10 Objects Falling on the LCU (Car) LCU (car) users shall be protected from falling objects.	O				O	X				*
3.4.11 LCU (Car) Ventilation Adequate ventilation shall be provided to the LCU (car).		O			O	X				
3.4.12 Fire/Smoke in LCU (Car) The interior of the LCU (car) shall be constructed of materials that are fire-resistant and that develop a low level of smoke.						X				

(Continued)



Table A-3
Cross-Referencing of GESRs in Part 3 and Elevator Sub-Systems

GESR #	Global essential safety requirement in Part 3	Elevator Sub-System [see A-3.2 for symbols]											
		B	C	E	G	H	L	M	Sf	Sp	W		
3.4.13	LCU (Car) in Flooded Areas Where there is a risk that the LCU (car) will descend into a flooded area, means shall be provided to detect and prevent descent into a flooded area.	O	X					O		O			
3.4.14	Stopping Means Inside the LCU (Car) Means located inside the LCU (car) of intentionally interrupting the movement of the LCU (car) by the user shall be allowed only, if necessary, on elevators with a partially enclosed LCU (car) or elevators for special applications.		X					X		O			
3.4.15	Landing Indication Means shall be provided to identify landings for users in the LCU (car).		X	X				X					
3.5 GESRs RELATED TO PERSONS IN WORKING AREAS													
3.5.1	Working Space Adequate and safe working space shall be provided.	O					O						X
3.5.2	Accessible Equipment All elevator equipment requiring maintenance shall be safely accessible to elevator personnel.		O	O	O	O	O	O	O	O	O	O	X
3.5.3	Access to and Egress from Working Spaces in the Hoistway Access to and egress from working spaces in or beyond the travel path shall be safe.	O	O	O		O	O						X
3.5.4	Strength of Working Areas Means shall be provided to accommodate and support the weight of elevator personnel and associated equipment in any designated working area.	O				O	O						X
3.5.5	Restrictions on Equipment in Elevator Spaces Only equipment related to the elevator installation or its protection shall be placed in the space containing the elevator equipment.	O				O	O						X
3.5.6	Falling from Working Areas Means shall be provided to sufficiently mitigate the risk to elevator personnel of falling from any working area.			O		O	O						X
3.5.7	LCU (Car) Movement under Control of Elevator Personnel Only elevator personnel shall be provided with means to prevent or to enable the movement of the LCU (car) when they are in the travel path. When elevator personnel are within reach of unprotected moving parts of the elevator, they shall be able to prevent or activate movement of the elevator equipment.		X			O	O		O				X

(Continued)

Table A-3 (Concluded)
Cross-Referencing of GESRs in Part 3 and Elevator Sub-Systems

GESR #	Global essential safety requirement in Part 3	Elevator Sub-System [see A-3.2 for symbols]									
		B	C	E	G	H	L	M	Sf	Sp	W
3.5.8	Uncontrolled, Unintended Equipment Movement inside the Hoistway Means shall be provided to protect elevator personnel from the effects related to uncontrolled or unintended movement of equipment inside the hoistway. Any acceleration or deceleration to which elevator personnel are subjected as a result of uncontrolled or unintended movement shall be limited to sufficiently mitigate the risk of harm.	X				O	O		O		X
3.5.9	Means of Protection from Various Hazards Means shall be provided to adequately protect elevator personnel in working spaces from the effects of shearing, crushing, abrasion, laceration, high temperature, or entrapment.	O	O	O	O	O	O	O	O	O	X
3.5.10	Falling Objects in Hoistway While in the hoistway, elevator personnel shall be adequately protected from falling objects.	O				O	O				X
3.5.11	Electric Shock in Working Spaces Equipment shall be designed and installed to minimize harm to elevator personnel due to the effects of electricity.		X	O		O	O	O	O		X
3.5.12	Illumination of Working Spaces All working spaces and access thereto shall be provided with adequate illumination for the use of elevator personnel.	O	O	O		O	O				X

NONMANDATORY APPENDIX A-4 TEMPLATE FOR CHECKING APPLICABLE GESRs

A-4.1 General

This table is a copy of Table A-3 with two columns (Ap and RA) added. It is provided to help users of this Code identify GESRs that may be applicable to the subject or system (such as an elevator system, sub-system, component, or function) when compliance is being verified.

A-4.2 References and Symbols in Table A-4

A-4.2.1 Symbols in the Table Heading Identifying Sub-Systems

- B** – Building, including its structure, hoistway, machinery space, and building equipment not provided by elevator contractor.
- C** – Control sub-system, including electrical equipment and wiring, except “Sf” (safety devices).
- E** – Landing and LCU (car) entrances.
- G** – Guiding of the LCU (car) and counterweight system.
- H** – Hoistway, including interior and surrounding guards or enclosures.
- L** – Load-carrying unit [LCU (car)], including its top, if applicable.
- M** – Machine, including braking system.
- Sf** – Safety devices.
- Sp** – Suspension of LCU (car) system.
- W** – Working area or space.
- Ap** – Identify with “Yes” or “+” if the GESR is applicable.
- RA** – Identify the case number (see first column in the Table C-1 template) related to the risk assessment case which proves (in column “residual risk”) that full compliance with the GESR is achieved, or enter any other symbol that will indicate compliance. Entering the case number is practical for later reference, such as by an AECO. Alternatively, in this column enter the ASME A17.1/CSA B44 Code requirement reference when full compliance with the relevant GESR is achieved by meeting that requirement.

A-4.2.2 Symbols in the Table Columns

- X** – A GESR that is primarily applicable to the elevator sub-system(s) identified in the heading.
- O** – A GESR that can be applicable to the elevator sub-system(s) identified in the heading.
- GESR #** – Cross-reference to Part 3 in this Code.



Table A-4
Cross-Referencing of GESRs in Part 3 and Elevator Sub-Systems

GESR #	Global essential safety requirement in Part 3	Elevator Sub-System [see A-4.2 for symbols]											
		B	C	E	G	H	L	M	Sf	Sp	W	Ap	RA
3.1 COMMON GESRs RELATED TO PERSONS AT DIFFERENT LOCATIONS													
3.1.1	Supports for Elevator Equipment The means used to support the elevator equipment shall be capable of sustaining all loads and forces (including impact forces) imposed during normal and emergency operations.	X			O	O				O	O		
3.1.2	Elevator Maintenance Where maintenance is required to ensure continued safety, appropriate instructions shall be provided, and elevator personnel shall perform any required work.	O	O	O	O	O	O	O	O	O	O		
3.1.3	Equipment Inaccessible to Users and Non-Users Equipment that is hazardous shall not be directly accessible to users and non-users.	O	O	O		X	O	O	O		O		
3.1.4	Floors of the LCU (Car) and Working Areas The floors of the LCU (car) and standing areas of workplaces shall minimize the risk of tripping and slipping.						X				X		
3.1.5	Hazards Due to Relative Movement Users and non-users shall be protected from the effects of shearing, crushing or abrasion, or other injuries due to (a) relative movement of the LCU (car) and external objects; and (b) relative movement of the elevator equipment.		O	X	O	X	X						
3.1.6	Locking Landing Doors and Closing of LCU (Car) Doors Any movement of the LCU (car) that is hazardous to persons shall be stopped if any hoistway door is open or unlocked or the LCU (car) door is not closed.		O	O			O	O	X				
3.1.7	Evacuation Means and procedures shall be provided to enable trapped users or elevator personnel to be safely released and evacuated.	O	O	X		O	X	O	O		X		
3.1.8	Sharp Edges Means shall be provided to sufficiently mitigate the risk to users and non-users of exposure to sharp edges.			X		O	X						
3.1.9	Hazards Arising from the Risk of Electrical Energy Where electricity is provided, means shall be provided to sufficiently mitigate the risk to users and non-users of exposure to electrical shock and related hazards.		X	O			O		O				

(Continued)

Table A-4
Cross-Referencing of GESRs in Part 3 and Elevator Sub-Systems

GESR #	Global essential safety requirement in Part 3	Elevator Sub-System [see A-4.2 for symbols]												
		B	C	E	G	H	L	M	Sf	Sp	W	Ap	RA	
3.1.10	Electromagnetic Compatibility The safe operation of an elevator shall not be influenced by electromagnetic interferences.		X							O		O		
3.1.11	Illumination of LCU (Car) and Landings LCU (car) and landings shall be provided with adequate illumination during use.	O		X			X							
3.1.12	Effects of Earthquake In areas subject to earthquake, means shall be provided to minimize the risk to users of the LCU (car) and elevator personnel of the foreseeable effects of earthquakes on the elevator equipment.	O	X		O	O	X	O	O	O	X			
3.1.13	Hazardous Materials The characteristics and quantity of material used for the manufacture and construction of the elevator shall not lead to hazardous situation.	O		O		X	X				X			
3.1.14	Environmental Influences Users and elevator personnel shall be protected from environmental influences.	O	O			O	X		O		X			
3.2 GESRs RELATED TO PERSONS ADJACENT TO THE ELEVATOR — FALLING INTO HOISTWAY														
3.2	Means shall be provided to prevent the risk of users, non-users, and elevator personnel falling into the hoistway.	O		X		X			O		X			
3.3 GESRs RELATED TO PERSONS AT THE ELEVATOR ENTRANCES														
3.3.1	Access and Egress Safe means of access and egress shall be provided to the LCU (car) at landings.	O	O	X			X		O					
3.3.2	Horizontal Sill-to-Sill Gap The horizontal gap between the sill of the LCU (car) and that of the landings shall be limited.			X	O		X							
3.3.3	Alignment of LCU (Car) and Landings When users enter or exit the LCU (car), its platform and landing floor shall be substantially aligned.		X	O			O	O						
3.3.4	Self-Evacuation from an LCU (Car) Self-evacuation of users shall be possible only when the LCU (car) is at or near a landing.		X	O		O	X		O					
3.3.5	Gap between the Landing Doors and LCU (Car) Doors The space between the landing doors and LCU (car) doors shall not allow the presence of users.			X			X							

(Continued)

Table A-4
Cross-Referencing of GESRs in Part 3 and Elevator Sub-Systems

GESR #	Global essential safety requirement in Part 3	Elevator Sub-System [see A-4.2 for symbols]														
		B	C	E	G	H	L	M	Sf	Sp	W	Ap	RA			
3.3.6	Means to Reopen Doors when LCU (Car) is at Landing Means shall be provided to reopen the LCU (car) and landing doors if their closing is obstructed when the LCU (car) is at the landing.		X	O				O			X					
3.4 GESRs RELATED TO PERSONS IN THE LCU (CAR)																
3.4.1	Strength and Size The LCU (car) shall accommodate and support the rated load and a reasonably foreseeable overload.				O		X		O							
3.4.2	LCU (car) Support/Suspension Means shall be provided to support the fully loaded LCU (car) and reasonably foreseeable overload.				O		X	O	O	X						
3.4.3	Overloaded LCU (Car) Means shall be provided to prevent an overloaded LCU (car) from attempting to leave a landing.		X				X	O	O							
3.4.4	Falling from an LCU (Car) Means shall be provided to prevent users from falling from the LCU (car).						X									
3.4.5	LCU (Car) Travel Path Limits The vertical travel of the LCU (car) shall be limited to prevent the LCU (car) from uncontrolled running beyond the travel path.		X		X		O	O	X	O						
3.4.6	Uncontrolled, Unintended Movement of an LCU (Car) Means shall be provided to limit uncontrolled or unintended movement of the LCU (car).		X	O			O	X	X							
3.4.7	LCU (Car) Collision with Objects in or beyond Travel Path Means shall be provided to avoid collision of the LCU (car) with any equipment in the travel path that could cause injuries to users.		O		O	O	X		X	O						
3.4.8	LCU (car) Horizontal and Rotational Motion Horizontal or rotational motion of the LCU (car) shall be limited to sufficiently mitigate the risk of injury to users and elevator personnel.		O	O		X	O	X					O			
3.4.9	Change of Speed or Acceleration Means shall be provided to ensure that any change of speed or acceleration of the LCU (car) shall be limited to minimize the risk of injury to the users.		X					O	X							
3.4.10	Objects Falling on the LCU (Car) LCU (car) users shall be protected from falling objects.		O				O	X					-			

(Continued)



Table A-4
Cross-Referencing of GESRs in Part 3 and Elevator Sub-Systems

GESR #	Global essential safety requirement in Part 3	Elevator Sub-System [see A-4.2 for symbols]														
		B	C	E	G	H	L	M	Sf	Sp	W	Ap	RA			
3.4.11	LCU (Car) Ventilation Adequate ventilation shall be provided to the LCU (car).		O				O	X								
3.4.12	Fire/Smoke in LCU (Car) The interior of the LCU (car) shall be constructed of materials that are fire-resistant and that develop a low level of smoke.							X								
3.4.13	LCU (Car) in Flooded Areas Where there is a risk that the LCU (car) will descend into a flooded area, means shall be provided to detect and prevent descent into a flooded area.	O	X					O		O						
3.4.14	Stopping Means Inside the LCU (Car) Means located inside the LCU (car) of intentionally interrupting the movement of the LCU (car) by the user shall be allowed only, if necessary, on elevators with a partially enclosed LCU (car) or elevators for special applications.		X					X		O						
3.4.15	Landing Indication Means shall be provided to identify landings for users in the LCU (car).		X	X				X								
3.5 GESRs RELATED TO PERSONS IN WORKING AREAS																
3.5.1	Working Space Adequate and safe working space shall be provided.	O					O						X			
3.5.2	Accessible Equipment All elevator equipment requiring maintenance shall be safely accessible to elevator personnel.		O	O	O	O	O	O	O	O	O	X				
3.5.3	Access to and Egress From Working Spaces in the Hoistway Access to and egress from working spaces in or beyond the travel path shall be safe.	O	O	O			O	O					X			
3.5.4	Strength of Working Areas Means shall be provided to accommodate and support the weight of elevator personnel and associated equipment in any designated working area.	O					O	O					X			
3.5.5	Restrictions on Equipment in Elevator Spaces Only equipment related to the elevator installation or its protection shall be placed in the space containing the elevator equipment.	O					O	O					X			
3.5.6	Falling from Working Areas Means shall be provided to sufficiently mitigate the risk to elevator personnel of falling from any working area.			O			O	O					X			

(Continued)



Table A-4 (Concluded)
Cross-Referencing of GESRs in Part 3 and Elevator Sub-Systems

GESR #	Global essential safety requirement in Part 3	Elevator Sub-System [see A-4.2 for symbols]													
		B	C	E	G	H	L	M	Sf	Sp	W	Ap	RA		
3.5.7	LCU (Car) Movement under Control of Elevator Personnel Only elevator personnel shall be provided with means to prevent or to enable the movement of the LCU (car) when they are in the travel path. When elevator personnel are within reach of unprotected moving parts of the elevator, they shall be able to prevent or activate movement of the elevator equipment.		X				O	O		O			X		
3.5.8	Uncontrolled, Unintended Equipment Movement inside the Hoistway Means shall be provided to protect elevator personnel from the effects related to uncontrolled or unintended movement of equipment inside the hoistway. Any acceleration or deceleration to which elevator personnel are subjected as a result of uncontrolled or unintended movement shall be limited to sufficiently mitigate the risk of harm.		X				O	O		O			X		
3.5.9	Means of Protection from Various Hazards Means shall be provided to adequately protect elevator personnel in working spaces from the effects of shearing, crushing, abrasion, laceration, high temperature, or entrapment.	O	O	O	O	O	O	O	O	O	O		X		
3.5.10	Falling Objects in Hoistway While in the hoistway, elevator personnel shall be adequately protected from falling objects.	O					O	O					X		
3.5.11	Electric Shock in Working Spaces Equipment shall be designed and installed to minimize harm to elevator personnel due to the effects of electricity.		X	O			O	O	O	O			X		
3.5.12	Illumination of Working Spaces All working spaces and access thereto shall be provided with adequate illumination for the use of elevator personnel.	O	O	O			O	O					X		

NONMANDATORY APPENDIX B SAFETY PARAMETERS

B-1

SPs related to each GESR are listed in the 4th column of Nonmandatory Appendix Table B-1. Most parameters are extracted from ASME A17.1/CSA B44 requirements that are referenced in the 3rd column. Other parameters are taken from ISO or Euronorm (EN) or other standards, with reference given also in the 3rd column.

B-2

SPs in the 4th column of Nonmandatory Appendix Table B-1 are examples of achieving compliance. The SPs given are not expected to be applicable to all designs. This list is not comprehensive, and designers might not find SPs in Nonmandatory Appendix Table B-1 for particular designs.

B-3

The table follows the sequence (and text) of GESRs (see Part 3 of this Code).

B-4

Where PES functions are new or deviate from those referenced in Nonmandatory Appendix Table B-1, ASME A17.1/CSA B44, methods for the determination of the required SIL should be performed according to IEC 61508-5. The mean target failure frequency for the highest severity for a single potential risk scenario should not exceed a frequency of 5×10^{-7} /year.

A non-SIL rated PES may be used if a target failure measure does not require an SIL 1 or greater.

If an SIL higher than SIL 3 is required, consideration should be given to system redesign such that the required target failure measure will be satisfied with SIL 3 or lower. Alternatively, risk reduction may be allocated over several SIL rated PES devices of SIL 3 or lower that have adequate levels of independence.

NOTE (B-1.4): Applications that require the use of a single safety function of SIL 4 are not typically used in the elevator industry because of the difficulty of achieving and maintaining such high levels of performance throughout the safety life cycle.



Nonmandatory Table B-1 SPs for Each GESR*

SP #	Part 3 GESRs and related notes	References to A17.1/B44 requirement or other standards	SPs
3.1	3.1 COMMON GESRs RELATED TO PERSONS AT DIFFERENT LOCATIONS		
3.1.1	3.1.1 Supports for Elevator Equipment The means used to support the elevator equipment shall be capable of sustaining all loads and forces (including impact forces) imposed during normal and emergency operation.	2.9.4.1	3.1.1.1 Stresses in machinery and sheave beams, floors, and supports not to exceed 80% of those permitted for static loads in (a) for Structural Steel: AISC Manual for Steel Construction – Allowable Stress Design – ninth edition, or CAN/CSA-S16.1; and (b) for Reinforced Concrete: ANSI/ACI 318 or CSA A23.3.
	NOTE (3.1.1): <i>The forces referred to in 3.1.1 are those that result from the intended use, and reasonably foreseeable overload, of the elevator during normal operation (loading, unloading, acceleration, braking, etc.) and emergency operation (safety operation, buffer impact, etc.)</i>		
	<i>Additional NOTE (3.1.1): For support of the LCU (car) and counterweight, if applicable, see GESR 3.4.2</i>		
		2.9.5	3.1.1.2 Deflections in machinery and sheave beams and supports under static load not to exceed 1/1666 of span.
		2.9.3.2	3.1.1.3 Anchor bolts to meet or exceed requirements of ASTM A307. Tensile stress in bolts ≤ 85 MPa, shear stress ≤ 60 MPa. Proportionately higher stresses permitted for strengths exceeding ASTM A307 requirements.
		2.23.2.1	3.1.1.4 Steel where used for rails, brackets, fishplates, and rail clips to have a tensile strength ≥ 380 MPa and an elongation $\geq 22\%$ in a length of 50 mm when measured in accordance with ASTM E8. Bolts to conform to ASTM A307, rivets to conform to ASTM A502. Where steels of greater than specified are used, the stress may be increased proportional to the UTS.
		2.23.5.1	3.1.1.5 Stresses in guide rails and joints for steel conforming with 3.1.1.4 not to exceed 105 MPa and deflections not to exceed 6 mm due to horizontal forces imposed during loading, unloading, or running, without impact.

* See 4.2.2.



Nonmandatory Table B-1 SPs for Each GESR*

SP #	Part 3 GESRs and related notes	References to A17.1/B44 requirement or other standards	SPs
		2.23.5.2	3.1.1.6 Brackets, fastenings, and supports to resist horizontal forces on rails with a deflection at point of support ≤ 3 mm.
		2.23.4.1	3.1.1.7 Bracket spacing for guide rails to be chosen to ensure that buckling loads, stresses, and deflections during safety application do not exceed equivalent values to those that would be obtained by using ASME A17.1/CSA B44, Fig 2.23.4.1-1 and Table 2.23.4.2, as applicable.
		2.23.4.3.1	3.1.1.8 Bracket spacing for guide rails for counterweights not provided with safeties and the mass of counterweights to be chosen to ensure that stresses and deflections do not exceed equivalent values to those that would be obtained by using ASME A17.1, Table 2.23.4.3.1.
		2.23.9.2.1(b)	3.1.1.9 If clip fastenings are used to secure brackets to building structure, the friction force in direction of motion to have a minimum factor of safety of 10. Horizontal shear to be resisted with a means having a factor of safety ≥ 5 .
		2.23.5.3	3.1.1.10 If the guide rails are used to retard the car or counterweight during emergency braking, the maximum stress with all loads acting simultaneously ≤ 190 MPa.
3.1.2	<p>3.1.2 Elevator Maintenance Where maintenance is required to ensure continued safety, appropriate instructions shall be provided, and elevator personnel shall perform any required work.</p> <p>NOTE (3.1.2): <i>This applies to the elevator system, sub-system, component, or function that is subject to wear and tear, not to those designed for maintenance-free operation. Adequate maintenance is a key element in keeping the elevator in safe operating condition. The objective of this GESR is to require that only elevator personnel perform maintenance work.</i></p>		3.1.2.1 GESR is self-explanatory.

Nonmandatory Table B-1 SPs for Each GESR*

SP #	Part 3 GESRs and related notes	References to A17.1/B44 requirement or other standards	SPs
3.1.3	<p>3.1.3 Equipment Inaccessible to Users and Non-Users Equipment that is hazardous shall not be directly accessible to users and non-users.</p> <p>NOTE (3.1.3): Locations that are not accessible include equipment behind an enclosure, a locked cover or door, or in an out-of-reach location.</p>	<p>2.1.1.3</p> <p>ISO 13852</p> <p>2.1.1.3</p>	<p>3.1.3.1 Place equipment out of reach of users and non-users:</p> <p>(a) at least 1500 mm away;</p> <p>(b) in compliance with ISO 13852 – Table 2; or</p> <p>(c) behind protection \geq 2400 mm high.</p>
3.1.4	<p>3.1.4 Floors of the LCU (Car) and Working Areas The floors of the LCU (car) and standing areas of workplaces shall minimize the risk of tripping and slipping.</p> <p>NOTE (3.1.4): LCU (car) and working area floors should be reasonably level, which means that they do not present a perceptible slope. When considering non-slip materials, attention should be paid to the fact that the roughness of a material does not remain consistent over time and can vary depending on housekeeping operations (e.g., cleaning)</p>	<p>2.14.1.9.2</p>	<p>3.1.4.1 No projections or depressions > 6 mm.</p> <p>NOTE (3.1.4.1): The user is referred also to ANSI A1264.2 and AS/NZS 4586-1999 for further information.</p>
3.1.5	<p>3.1.5 Hazards Due to Relative Movement Users and non-users shall be protected from the effects of shearing, crushing or abrasion, or other injuries due to</p> <p>(a) relative movement of the LCU (car) and external objects; and</p> <p>(b) relative movement of the elevator equipment.</p> <p>NOTES (3.1.5):</p> <p>(1) For elevator personnel, see 3.5.9.</p> <p>(2) This GESR addresses the safety of persons located inside and outside the LCU (car).</p> <p><i>Additional Note: (3) This GESR also requires protection for non-users located below the hoistway in case of catastrophic failure resulting in free-fall of CWT or any other heavy elevator equipment.</i></p>	<p>2.1.1.3</p> <p>ISO 13852</p> <p>2.1.1.3</p>	<p>3.1.5.1 Place equipment out of reach of users and non-users:</p> <p>(a) at least 1500 mm away;</p> <p>(b) in compliance with ISO 13852 – Table 2; or</p> <p>(c) behind protection \geq 2400 mm high.</p>



Nonmandatory Table B-1 SPs for Each GESR*

SP #	Part 3 GESRs and related notes	References to A17.1/B44 requirement or other standards	SPs
3.1.6	<p>3.1.6 Locking Landing Doors and Closing LCU (Car) Doors Any movement of the LCU (car) that is hazardous to persons shall be stopped if any hoistway door is open or unlocked or the LCU (car) door is not closed.</p> <p>NOTES (3.1.6): (1) <i>Hoistway and car doors, including auxiliary doors or covers intended for use by elevator personnel only (e.g., evacuation doors), must be considered.</i> (2) <i>Leveling, re-leveling (as well as truck load operation), and hoistway access operation are not considered to be hazardous movements.</i></p>	2.12.2.2	<p>3.1.6.1 If hoistway door is open ≥ 10 mm, car must not move if it is outside the following zones:</p> <p>(a) 75 mm for static control;</p> <p>(b) 450 mm for other controls; and</p> <p>(c) 1700 mm for trucking zones.</p>
		2.26.1.6.7	(a) 75 mm for static control;
		2.26.1.6.3	(b) 450 mm for other controls; and
		2.26.1.6.4	(c) 1700 mm for trucking zones.
		2.26.1.6.6	3.1.6.2 Within the zones, car speed is 0.75 m/s if hoistway door is open ≥ 10 mm or car door is open ≥ 50 mm.
		2.14.4.11	3.1.6.3 If PES devices are used for detection of the following states of doors, the devices should have SIL ≥ 3 :
		2.26.2.14	(a) closed and locked hoistway doors;
		2.26.2.15	(b) closed position of car door; and
		2.26.2.28	(c) closed and locked position of car door.
		2.26.2.18	3.1.6.4 If PES devices are used for determination of the closed state of the following openings, the devices should have SIL ≥ 2 :
		2.26.2.25	(a) car top emergency exit;
		2.26.2.26	(b) blind hoistway access door; and (c) pit access door.
3.1.7	<p>3.1.7 Evacuation Means and procedures shall be provided to enable trapped users or elevator personnel to be safely released and evacuated.</p> <p>NOTE (3.1.7): <i>The elevator system should have means that would permit the movement of the LCU (car), under control of elevator personnel, to the point of an evacuation opening. Alternative means that do not require movement of the LCU (car) are not excluded. Extreme cases of LCU (car) blockage (due to safety setting, material damaged due to earthquakes, etc.) can require external means, appropriate instructions and tooling.</i></p>	2.14.1.5.1	3.1.7.1 If emergency exits are used:
		2.11.1.2	(a) car top – minimum sizes: <ul style="list-style-type: none"> • area 0.26 m²; and • any side 400 mm.
		2.5.1.5.1(b)	(b) single blind hoistway – at least every 11 m provide doors in the hoistway enclosure of minimum size: <ul style="list-style-type: none"> • width 700 mm; and • height 2030 mm.
		2.14.4.5.1	(c) car sill to hoistway enclosure clearance < 125 mm for full width of car opening.
		2.26.2.18	(d) car door face to hoistway door face distance < 140 mm.
		2.26.2.25	3.1.7.2 If PES devices are used for determination of the closed state of the following openings, the devices should have SIL ≥ 2 :
2.26.2.18	(a) car top emergency exit; and		
2.26.2.25	(b) blind hoistway access door.		

Nonmandatory Table B-1 SPs for Each GESR*

SP #	Part 3 GESRs and related notes	References to A17.1/B44 requirement or other standards	SPs
3.1.8	<p>3.1.8 Sharp Edges Means shall be provided to sufficiently mitigate the risk to users and non-users of exposure to sharp edges.</p> <p>NOTE (3.1.8): <i>For elevator personnel, see 3.5.</i></p>	2.11.11.5.5	<p>3.1.8.1 No areas on surfaces to be depressed or raised > 3 mm.</p> <p>3.1.8.2 Edges must be beveled ≤ 30 degrees to surface.</p>
3.1.9	<p>3.1.9 Hazards Arising from the Risk of Electrical Shock Where electricity is provided, means shall be provided to sufficiently mitigate the risk to users and non-users of exposure to electrical shock and related hazards.</p> <p>NOTES (3.1.9): (1) <i>CSA B44.1/ASME A17.5, ANSI/NFPA 70, and/or CSA C22.1 embody the fundamental principles of protection for safety that encompass protection against electric shock, protection against thermal effects, protection against overcurrent, protection against fault current, and protection against over-voltage. See also Section 131 of IEC 60364-1.</i> (2) <i>For elevator personnel, see 3.5.</i></p>	2.26.4.1 2.26.4.2	<p>3.1.9.1 Meet applicable requirements of</p> <p>(a) NFPA 70 or CSA 22.1 as applicable; and</p> <p>(b) CSA B44.1/ASME A17.5 as applicable.</p>
3.1.10	<p>3.1.10 Electromagnetic Compatibility The safe operation of an elevator shall not be influenced by electromagnetic interferences.</p> <p>NOTE (3.1.10): <i>The immunity should be sufficient to prevent unsafe situations if the elevator is submitted to foreseeable radiation. "Immunity" includes immunity to internal influences (self-generated radiation) and immunity to external influences.</i></p>	2.26.4.4 EN 12016	3.1.10.1 Meet applicable requirements of EN 12016 as specified in ASME A17.1/CSA B44.
3.1.11	<p>3.1.11 Illumination of LCU (Car) and Landings The LCU (car) and landings shall be provided with adequate illumination during use.</p>	2.14.7.1.2 2.14.7.1.3 2.11.10.2	<p>3.1.11.1 Illumination:</p> <p>(a) at car threshold ≥ 50 lx;</p> <p>(b) in car 1225 mm above floor, 300 mm from operating device ≥ 2 lx for 4 h during power loss. See also CSA C22.2 No. 141; and</p> <p>(c) at landing sills ≥ 100 lx.</p>



Nonmandatory Table B-1 SPs for Each GESR*

SP #	Part 3 GESRs and related notes	References to A17.1/B44 requirement or other standards	SPs
	<p>NOTE (3.1.11): "Adequate illumination" means that the level of light is sufficient for safe access and operation of the elevator control devices, including the following:</p> <ul style="list-style-type: none"> (a) detecting leveling inaccuracy; (b) operating landing and LCU (car) controls; and (c) mitigating user's panic in the case of power outage. 		
3.1.12	<p>3.1.12 Effects of Earthquake In areas subject to earthquake, means shall be provided to minimize the risk to users, when inside the LCU (car), and elevator personnel of the foreseeable effects of earthquakes on the elevator equipment.</p> <p>NOTE (3.1.12): The effects on the safety of users and elevator personnel need to be considered at all stages: during the earthquake (as much as possible), during rescue from a stalled LCU (car), and when the elevator is returned to normal operation. This assumes that there is no major building failure.</p>	8.4 ASCE 7	<p>3.1.12.1 Meet requirements of building code, depending on seismic risk zone, soil conditions, building use, building type, and location of the equipment in the building.</p>
3.1.13	<p>3.1.13 Hazardous Materials The characteristics and quantity of material used for the manufacture and construction of the elevator shall not lead to hazardous situations.</p> <p>NOTE (3.1.13): Hazardous situations for users, non-users, and elevator personnel refer to toxicity, fumes, exposure to chemicals, flammability, exposure to asbestos, etc.</p>	2.14.2.1.1 2.14.2.1.5 2.14.2.1.3 2.14.2.1 2.14.2.1(a) and (b) 2.14.2.1(b)(4)	<p>3.1.13.1 U.S. For elevator car enclosures:</p> <ul style="list-style-type: none"> (a) Flame spread rating ≤ 75. (b) Smoke development ≤ 450. (c) Tests for (1)(a) and (1)(b) per ASTM E84, UL 723, or NFPA 255. (d) Floor covering radiant flux $\geq 0.45 \text{ W/cm}^2$ per ASTM E648. (e) Napped, tufted, woven, or looped materials on walls to meet 8.3.7.3 and 8.3.7.4 of ASME A17.1/CSA B44. <p>3.1.13.2 Canada All cars except as in B 3.1.13.2(b):</p> <ul style="list-style-type: none"> (a) Flame spread rating: <ul style="list-style-type: none"> • walls: ≤ 150 per CAN/ULC-S102; • floors: ≤ 300 per CAN/ULC-S102.2; and • padding per National Fire Code, Subsection 2.3.2.

Nonmandatory Table B-1 SPs for Each GESR*

SP #	Part 3 GESRs and related notes	References to A17.1/B44 requirement or other standards	SPs
			(b) Firefighters' cars:
		2.14.2.1(c)(1) 2.14.2.1(c)(2)	<ul style="list-style-type: none"> • flame spread rating for walls: ≤ 25; and • smoke development: <ul style="list-style-type: none"> • walls: ≤ 100; and • floors: ≤ 300.
3.1.14	3.1.14 Environmental Influences Users and elevator personnel shall be protected from environmental influences.	2.14.2.3.3	3.1.14.1 Forced ventilation on observation elevators ≥ 1 air change per minute (based on net inside car volume).
	NOTE (3.1.14): <i>Environmental influences include the foreseeable weather conditions of the area where the elevator is installed. Users and elevator personnel should be protected against direct exposure to the influences (e.g., by heating or cooling the LCU (car) or working space). The safety of users, elevator personnel, and emergency personnel should be considered in the event of a fire. In addition, there should be adequate protection of safety-related elevator elements that are susceptible to weather conditions.</i>	2.14.2.3.1	3.1.14.2 Natural ventilation area $\geq 3.5\%$ inside car floor area (equally divided between top and bottom of car enclosure).
		2.27.3 to 2.27.8, and 3.27.1 to 3.27.3	3.1.14.3 Meet applicable requirements of ASME A17.1/CSA B44.
3.2	3.2 GESRs RELATED TO PERSONS ADJACENT TO THE ELEVATOR — FALLING INTO HOISTWAY		
3.2	3.2.1 Means shall be provided to prevent the risk of users, non-users, and elevator personnel falling into the hoistway.	2.11.11.8	3.2.1.1 See also parameters for 3.1.5. 3.2.1.2 If entrances are provided: <ol style="list-style-type: none"> (a) the entrance panel(s) to withstand a horizontal force of 5000 N applied at right angles to the panel, distributed over 300 mm x 300 mm area, in the direction of hoistway, with maximum displacement of 20 mm; and (b) the entrance panel(s) to withstand a vertical force of 1000 N while a horizontal force of 1100 N is applied at right angles to the panel, distributed over 300 mm x 300 mm area, in the direction of the hoistway, without permanent deformation or detachment.
	NOTES (3.2): (1) <i>This GESR addresses the risk of falling into the hoistway from</i> <ol style="list-style-type: none"> (a) <i>surrounding floors;</i> <i>and</i> (b) <i>landing doors when the LCU (car) is absent.</i> (2) <i>This GESR also applies to emergency personnel.</i>		3.2.1.3 For other surrounding areas: Provide guarding complying with applicable building codes for galleries or balconies or open staircases.



Nonmandatory Table B-1 SPs for Each GESR*

SP #	Part 3 GESRs and related notes	References to A17.1/B44 requirement or other standards	SPs
3.3	3.3 GESRs RELATED TO PERSONS AT THE ELEVATOR ENTRANCE		
3.3.1	3.3.1 Access and Egress Safe means of access and egress shall be provided to the LCU (car) at landings. NOTE (3.3.1): <i>This is applicable to the process of entering and leaving the LCU (car) during normal use and during Firefighters' Emergency Operations of the elevator. It suggests that adequate spaces, dimensions, operational instructions, and correct relative positioning of the LCU (car) at the landing should be provided.</i>	2.26.1.6.7 2.26.1.6.6 3.26.3.2 2.26.11(a) ICC/ANSI A117.1 and ADAAG 2.26.11(b) ICC/ANSI A117.1 and ADAAG 2.11.1.1 2.11.10.1 2.11.7.2.1 2.11.7.2.2 2.11.11.5.1 2.14.5.6 2.11.11.5.2 2.11.11.5.4 2.11.11.5.5 2.13.4.2.1	3.3.1.1 No movement with open doors 75 mm above or below the landing. 3.3.1.2 Leveling speed to be limited within leveling zone: (a) ≤ 0.75 m/s for static control electronic elevators; and (b) ≤ 0.125 m/s for hydraulic elevators. 3.3.1.3 Out of level distance ≤ 13 mm on initial stop. 3.3.1.4 Car should re-level if out of level > 25 mm; or if ICC/ANSI A117.1, ADAAG, or ASME A17.1/CSA B44, Appendix E, applies, > 13 mm. 3.3.1.5 Hoistway landing opening ≥ 2030 mm high, ≥ 800 mm wide. 3.3.1.6 If a car leveling device is provided, landing sill guards must be metal ≥ 1.4 mm thick extending ≥ 75 mm below leveling zone. Bottom of guard must be beveled in range 60° to 70° from horizontal. 3.3.1.7 Glass in hoistway doors: (a) to conform with 16 CFR Part 1201 or CAN/CGSB-12.1; and (b) to be $\geq 60\%$ of visible panel surface area. 3.3.1.8 Door panels to overlap top and sides of opening and each other in multispeed entrances, by ≥ 13 mm. 3.3.1.9 Clearances between moving panels, relative to each other and stationary members, ≤ 10 mm. 3.3.1.10 If provided on center opening door edges, resilient members to interlock ≤ 10 mm. 3.3.1.11 No areas depressed or raised > 3 mm. Edges beveled $\leq 30^\circ$ to panel surface.

**Nonmandatory Table B-1
 SPs for Each GESR***

SP #	Part 3 GESRs and related notes	References to A17.1/B44 requirement or other standards	SPs
			<p>3.3.1.12 Closing KE of automatic doors:</p> <p>(a) With reopening device:</p> <ul style="list-style-type: none"> • KE (peak) ≤ 23 J based on peak closing speed in the code zone distance; and • KE (average) ≤ 10 J based on average closing speed in the code zone distance. <p>(b) Without a reopening device:</p> <ul style="list-style-type: none"> • KE (peak) ≤ 8 J based on peak closing speed in the code zone distance; and • KE (average) ≤ 3.5 J based on the average closing speed in the code zone distance.
		2.13.4.2.2	<p>3.3.1.13 Code zone distance:</p> <p>(a) For side slide doors – 50 mm from fully open jamb line to 50 mm from fully closed jamb line.</p> <p>(b) For center opening doors – 25 mm from fully open jamb line to 25 mm from meeting point of the doors.</p>
		2.13.4.2.3	3.3.1.14 Door closing force ≤ 135 N measured at any point between 1/3 and 2/3 of its travel.
		2.27.3 to 2.27.8, and 3.27.1 to 3.27.3	3.3.1.15 Meet applicable requirements of ASME A17.1/CSA B44.
3.3.2	<p>3.3.2 Horizontal Sill-to-Sill Gap The horizontal gap between the sill of the LCU (car) and that of the landings shall be limited.</p> <p>NOTE (3.3.2): <i>The measurement is taken in direction of motion of users traversing the sill. Children who are able to walk should be considered. The sizes of wheelchair wheels and walking aids should also be taken into account.</i></p>	2.5.1.4	3.3.2.1 Gap ≤ 32 mm.
3.3.3	<p>3.3.3 Alignment of LCU (Car) and Landing When users enter or exit the LCU (car), its platform and landing floor shall be substantially aligned.</p> <p>NOTE (3.3.3): <i>The step caused by the variation of the LCU (car) load should be limited to avoid stumbling on the part of users; the step should be small enough to allow safe access for all users, including persons with impaired mobility.</i></p>		3.3.3.1 See SP 3.3.1.3.

Nonmandatory Table B-1 SPs for Each GESR*

SP #	Part 3 GESRs and related notes	References to A17.1/B44 requirement or other standards	SPs
3.3.4	<p>3.3.4 Self-Evacuation from an LCU (Car) Self-evacuation of users shall be possible only when the LCU (car) is at or near a landing.</p> <p>NOTE (3.3.4): “Near a landing” means that the LCU (car) is not too far away from the landing and that the risk of tripping or falling is minimal. Furthermore, any gaps between the LCU (car) entrance opening, when the LCU (car) entrance is opened manually by users attempting self-evacuation, and the hoistway enclosure or the landing entrance, which faces the opened LCU (car) entrance, should be as small as possible, to prevent users from passing through the gaps and from falling into the hoistway.</p>	<p>2.14.5.7 2.12.5 2.26.2.28</p>	<p>3.3.4.1 Doors to be openable > 100 mm from inside the car only when car floor is within 175 mm of the landing floor. Manual force to open doors ≤ 330 N.</p> <p>3.3.4.2 If PES device is used to detect closed and locked position of car door: SIL ≥ 3.</p>
3.3.5	<p>3.3.5 Gap between the Landing Doors and LCU (Car) Doors The space between the landing doors and LCU (car) doors shall not allow the presence of users.</p> <p>NOTE (3.3.5): This GESR aims to prevent persons, including children, from entering into the space between the LCU (car) and landing doors. The following are examples where this situation can arise:</p> <ul style="list-style-type: none"> (a) multiple panels on the LCU (car) and landing doors, with loose synchronization; or (b) combinations of swing landing doors and sliding LCU (car) doors. 	<p>2.14.4.5.1</p>	<p>3.3.5.1 Swing hoistway door/car gate gap ≤ 100 mm.</p> <p>3.3.5.2 Swing hoistway door/car door gap ≤ 140 mm.</p> <p>3.3.5.3 Slide hoistway door/car door or gate gap ≤ 140 mm.</p>
3.3.6	<p>3.3.6 Means to Reopen Doors when LCU (Car) is at Landing Means shall be provided to reopen the LCU (car) and landing doors if their closing is obstructed when the LCU (car) is at the landing.</p>	<p>2.13.5.1</p>	<p>3.3.6.1 Door reopening device to be effective if kinetic energy > 3.5 J.</p>



Nonmandatory Table B-1 SPs for Each GESR*

SP #	Part 3 GESRs and related notes	References to A17.1/B44 requirement or other standards	SPs
	<p>NOTE (3.3.6): <i>Obstacles interfering with door movement should be detected. The movement of the doors and the LCU (car) should be prevented until the obstacle is removed or door closing speed and force is limited. Examples of obstacles are parts of a user's body, trolleys, wheelchairs, etc.</i></p>		
3.4	3.4 GESRs RELATED TO PERSONS IN THE LCU (CAR)		
3.4.1	<p>3.4.1 Strength and Size The LCU (car) shall accommodate and support the rated load and a reasonably foreseeable overload.</p> <p>NOTE (3.4.1): <i>This GESR is primarily addressing transportation of people. "Accommodate" in this context means to provide space (volume) for the intended number of users, considering the dimension and weight of persons. The foreseeable overload, in terms of users, means:</i></p> <p>(1) <i>the load normally carried by users (e.g., briefcase, luggage, but without tools such as trolleys);</i> (2) <i>the possibility of users taller or heavier than average; and</i> (3) <i>the possibility of more users than the LCU (car) is designed for.</i></p>	<p>8.2.1.1 8.2.1.2</p> <p>2.16.2.2</p> <p>2.16.8</p> <p>Table 2.15.10.1</p> <p>2.15.6.2</p> <p>2.15.6.2.3</p> <p>2.15.10.1 Table 2.15.10.1</p>	<p>3.4.1.1 Minimum rated load for passenger elevators and freight elevators permitted to carry passengers to be determined using 8.2.1.1 and 8.2.1.2, as applicable.</p> <p>3.4.1.2 Minimum rated load for Class A and C freight elevators $\geq 240 \text{ kg/m}^2$ of net inside area. For Class B freight elevators $\geq 145 \text{ kg/m}^2$.</p> <p>3.4.1.3 Reasonably foreseeable overload for passenger elevators and freight elevators permitted to carry passengers = 25% rated load.</p> <p>3.4.1.4 Strength of car frame, platform members, and connections based on rated (static) load.</p> <p>(a) Maximum allowable stresses in car frames, platform members, and connections to conform with Table 2.15.10.1 for the following materials:</p> <ul style="list-style-type: none"> • rolled and formed steel conforming to ASTM A36 or ASTM A283 Grade D or CAN/CSA-G40.21; • forged steel conforming to ASTM A668 Class B; • cast steel conforming to ASTM A27 Grade 60/30; • steel rivets conforming to ASTM A502; and • steel bolts and rods conforming to ASTM A307. <p>(b) Steels having a % elongation in 50 mm $\geq 20\%$ per ASTM E8 and materials other than steels to have maximum allowable stresses listed in Table 2.15.10.1 adjusted proportionally, based on the ratio of ultimate tensile strengths.</p>

Nonmandatory Table B-1 SPs for Each GESR*

SP #	Part 3 GESRs and related notes	References to A17.1/B44 requirement or other standards	SPs
		2.15.11	(c) The deflection of crosshead, plank, and platform members, based on the rated (static) load imposed on them, to be $\leq 1/960$ of span.
		8.2.2.5.3	(d) The moment of inertia of uprights, based on rated (static) load, to be \geq value determined using 8.2.2.5.3.
		2.15.7.3.3	(e) Welding where used to conform to 8.8.
		2.15.6.4	(f) Wood used for platform stringers, floors, and sub-floors to conform to the applicable requirements of <ul style="list-style-type: none"> • ASTM D245, Structural Grades of Lumber; and • ASTM D198, Static Tests of Structural Timber. • ANSI Voluntary Product Standard PS-1-74 or CSA O151, Softwood, Plywood, Construction and Industrial.
3.4.2	<p>3.4.2 LCU (Car) Support/Suspension Means shall be provided to support the fully loaded LCU (car) and a reasonably foreseeable overload.</p> <p>NOTE (3.4.2): <i>This addresses the strength and failure of the suspension means, when the LCU (car) is loaded with its rated load. It is, however, understood that the integrity of the elevator would be maintained if the foreseeable overload condition were reached. The rated performances, however, can be affected if the rated load is exceeded</i></p>	<p style="text-align: center;">2.24.3</p> <p style="text-align: center;">2.24.3.1</p> <p style="text-align: center;">ASME A17/CSA B44</p> <p style="text-align: center;">2.20.3 Table 2.20.3</p> <p style="text-align: center;">2.20.9.1(a)(2)</p> <p style="text-align: center;">3.18.2.1.1</p>	<p>3.4.2.1 Driving machines, sheaves and drums:</p> <p>(a) Based on rated load, the factor of safety (FOS) for materials with percentage elongation in 50 mm per ASTM E8 to be as follows:</p> <ul style="list-style-type: none"> • FOS ≥ 8 for materials with % elongation $\geq 14\%$; and • FOS ≥ 10 for material with % elongation $< 14\%$. <p>(b) The factor of safety for components subjected to alternating or reversing stresses to be ≥ 1.5 using endurance strength based on 10^7 cycles.</p> <p>3.4.2.2 Suspension means to meet applicable requirements of ASME A17.1/CSA B44.</p> <p>(a) Steel wire suspension ropes minimum factors of safety to meet Table 2.20.3. Factor of safety to be calculated per formula in 2.20.3.</p> <p>(b) Rope fastenings strength $\geq 80\%$ ultimate breaking strength of suspension member.</p> <p>3.4.2.3 Hydraulic jacks and pressure piping:</p> <p>(a) Hydraulic plungers:</p> <ul style="list-style-type: none"> • tensile, compressive, bending and torsional loading factors of safety ≥ 5 based on ultimate tensile strength;

Nonmandatory Table B-1 SPs for Each GESR*

SP #	Part 3 GESRs and related notes	References to A17.1/B44 requirement or other standards	SPs
		8.2.8.1 8.2.8.1.3 8.2.8.5.1 8.2.8.5.2 3.19.3.3.1	<ul style="list-style-type: none"> • for elastic stability, steel plungers to meet requirements of 8.2.8.1; and • plungers subject to external pressure to meet requirements of 8.2.8.1.3. <p>(b) Hydraulic cylinders, piping and components subject to internal pressure:</p> <ul style="list-style-type: none"> • minimum FOS to be determined using 8.2.8.5.1; and • allowable stress to be determined using 8.2.8.5.2 <p>(c) Flexible pressure hose to have a minimum FOS of 10.</p>
3.4.3	<p>3.4.3 Overloaded LCU (Car) Means shall be provided to prevent an overloaded LCU (car) from attempting to leave a landing.</p> <p>NOTE (3.4.3): <i>In this context “to prevent from attempting to leave a landing” means that the drive system (motor controller) of the hoisting machine will not be activated. When the overload condition is detected, no command will be processed. This does not cover rope stretch, loss of traction, etc. It is, however, understood that the integrity of the elevator would be maintained if the foreseeable overload condition were reached.</i></p>		<p>3.4.3.1 GESR is self-explanatory.</p>
3.4.4	<p>3.4.4 Falling from an LCU (Car) Means shall be provided to prevent users from falling from the LCU (car).</p> <p>NOTE (3.4.4): <i>Compliance with this GESR can be achieved by guards, barriers, or walls around the perimeter of the LCU (car) platform. Protection at any opening between the LCU (car) and the hoistway walls that a user could pass through is also required by this GESR. A typical opening is the gap between the edges of the LCU (car) and the landing door panels.</i></p>	2.14.1.3	<p>3.4.4.1 Barriers: Strength 330 N, applied perpendicular to any point along the LCU enclosure.</p>



Nonmandatory Table B-1 SPs for Each GESR*

SP #	Part 3 GESRs and related notes	References to A17.1/B44 requirement or other standards	SPs
3.4.5	<p>3.4.5 LCU (Car) Travel Path Limits The vertical travel of the LCU (car) shall be limited to prevent the LCU (car) from uncontrolled running beyond the travel path.</p> <p>NOTE (3.4.5): Means should be provided for safe stopping of the LCU (car) at the end of the travel path. Safe stopping involves no damage to the equipment and no harm to passengers in the LCU (car). The "end of travel path" includes a certain overrun from the terminal landing position.</p>	<p>2.26.2.11</p> <p>2.26.2.12</p> <p>2.26.2.16</p>	<p>3.4.5.1 If PES devices are used for following functions, the device should have:</p> <p>(a) SIL ≥ 1 to remove power from the driving means at the terminal limits; and</p> <p>(b) SIL ≥ 2 to limit speed at terminals to rated striking speed for end of terminal retardation means (buffer) not designed for rated speed; or</p> <p>(c) SIL ≥ 1 to limit speed at terminals to rated striking speed for end of terminal retardation means (buffer) designed for rated speed.</p> <p>NOTE (A 3.4.5.1): This Code cannot specify distances and spaces beyond terminal landings. It is up to the designer to decide in accordance with clarifications in NOTE (3.4.5).</p>
3.4.6	<p>3.4.6 Uncontrolled, Unintended Movement of an LCU (Car) Means shall be provided to limit uncontrolled or unintended movement of the LCU (car).</p> <p>NOTE (3.4.6): This GESR aims to protect against the effects resulting from the movement of the LCU (car) at a speed exceeding the designed speed and also to prevent effects resulting from unexpected starts of LCU (car) movement. Examples of such occurrences are travel of the LCU (car) towards terminal landings at a speed exceeding its rated speed, or movement of the LCU (car) away from a landing when doors are open and users are entering or exiting. An example of the foreseeable failures that can cause such occurrences is the breakdown in elevator components such as speed control, driving machine, or braking system. Such failures could occur as a result of mechanical or electrical control malfunctions.</p>	<p>2.18.4.2</p> <p>Table 2.18.2.1</p> <p>2.18.4.2.1</p> <p>2.18.4.2.2</p> <p>2.18.4.2.3</p> <p>2.18.4.2.4</p> <p>Table 2.18.2.1</p> <p>2.26.2.10</p> <p>2.19.1.2(a)</p> <p>2.19.3.2(a)</p>	<p>3.4.6.1 Detection of overspeed in down direction and removal of power driving machine motor and brake is required for rated speed, V:</p> <p>(a) For $0.75 < V \leq 2.5$ m/s act when elevator speed $\leq 90\%$ of speed in Table 2.18.2.1.</p> <p>(b) For $V > 2.5$ m/s act when elevator speed $\leq 95\%$ of speed in Table 2.18.2.1.</p> <p>(c) For elevators with static control act when elevator speed $\leq 90\%$ of speed in Table 2.18.2.1.</p> <p>3.4.6.2 Detection of overspeed in up direction and removal of power from driving machine motor and applying brake is required for speed $\leq 100\%$ of speed set in down direction per Table 2.18.2.1.</p> <p>3.4.6.3 If a PES device is used to detect car overspeed in SP 3.4.6.1 and SP 3.4.6.2 up or down directions, the device to have SIL ≥ 2.</p> <p>3.4.6.4 Detect overspeed up direction at speed ≤ 1.1 times governor trip speed in Table 2.18.2.1:</p> <p>(a) Decelerate LCU at any rate ≤ 9.8 m/s² with any load to 125% rated load.</p>



Nonmandatory Table B-1 SPs for Each GESR*

SP #	Part 3 GESRs and related notes	References to A17.1/B44 requirement or other standards	SPs
		2.26.2.29 2.19.2.2(b)	(b) If a PES device is used for function in 3.4.6.4(a), the device to have SIL ≥ 2 .
		2.26.2.30	3.4.6.5 Detect unexpected LCU movement away from landing from rest, with doors open: (a) Stop and hold LCU with any load up to 125% of rated load within 1220 mm up or down. (b) If a PES device is used to detect movement in 3.4.6.5(a), the device to have SIL ≥ 2 .
3.4.7	<p>3.4.7 LCU (Car) Collision with Objects in or beyond Travel Path Means shall be provided to avoid collision of the LCU (car) with any equipment in the travel path that could cause injuries to users.</p> <p>NOTE (3.4.7): Means should be provided to prevent the LCU (car) from colliding with any equipment in the hoistway. There should be LCU (car) guards or enclosures of adequate strength to avoid dangerous deflection due to horizontal forces. Deflection and deformation of the guards or enclosure should be limited so that they do not create a hazardous situation. This GESR also addresses cases where the LCU (car) or counterweight reaches the structural terminals of the hoistway. Eventual impact should be buffered so that it is not harmful.</p>	2.5.1.1 2.5.1.2 2.5.1.2 2.5.1.2 2.5.1.3 2.5.1.4	<p>3.4.7.1 Horizontal clearances:</p> <p>(a) car side to hoistway enclosure > 20 mm; (b) car to counterweight ≥ 25 mm; (c) car to CWT guard ≥ 20 mm; (d) CWT to CWT guard ≥ 20 mm; (e) CWT to hoistway enclosure ≥ 20 mm; (f) between two cars > 50 mm; and (g) car to landing sills > 13 mm, < 32 mm, side guide; and (h) car to landing sills > 20 mm, < 32 mm, corner guide.</p> <p>3.4.7.2 If a PES device is for detection of the following malfunctions, and/or subsequent stopping of the machine, the device should have:</p> <p>(a) for loss of tension in, and/or guidance of, cabling (such as compensating ropes) in the hoistway attached to the car SIL ≥ 2; and (b) for potential malfunction of the stand-by means for mechanical retardation of car:</p> <ul style="list-style-type: none"> • SIL ≥ 1 in the travel path (such as buffer on type C safeties not fully extended or lacks oil); or • SIL ≥ 3 beyond the travel path (such as gas-return oil buffer not fully extended).
3.4.8	<p>3.4.8 LCU (Car) Horizontal and Rotational Motion Horizontal or rotational motion of the LCU (car) shall be limited to sufficiently mitigate the risk of injury to users and elevator personnel.</p> <p>NOTE (3.4.8): Horizontal and rotational free movement of the LCU (car) is to be limited to prevent users from losing balance and falling.</p>	5.1.20.6.1 5.1.20.6.2	<p>3.4.8.1 Average horizontal acceleration ≤ 0.98 m/s².</p> <p>3.4.8.2 No peak horizontal acceleration > 0.98 m/s² should have a time duration exceeding 0.125 s.</p>



Nonmandatory Table B-1 SPs for Each GESR*

SP #	Part 3 GESRs and related notes	References to A17.1/B44 requirement or other standards	SPs
3.4.9	<p>3.4.9 Change of Speed or Acceleration Means shall be provided to ensure that any change of speed or acceleration of the LCU (car) shall be limited to minimize the risk of injury to the users.</p> <p>NOTE (3.4.9): <i>This covers changes of speed and acceleration of the LCU (car) for both normal and emergency operations. In the case of an extreme emergency [such as stopping a free-falling LCU (car)], the possibility of minor injuries could be tolerated, due to the extremely remote probability of such an occurrence.</i></p>	<p>8.2.6</p> <p>2.22.4.1.1</p> <p>2.22.4.2</p>	<p>3.4.9.1 Deceleration rates $\leq 9.81 \text{ m/s}^2$.</p> <p>3.4.9.2 Average retardation with 115% of rated speed $\leq 9.81 \text{ m/s}^2$.</p> <p>3.4.9.3 No peak retardations $> 24.5 \text{ m/s}^2$ for durations $> 0.04 \text{ s}$, with 115% of rated speed.</p>
3.4.10	<p>3.4.10 Objects Falling on the LCU (Car) LCU (car) users shall be protected from falling objects.</p> <p>NOTE (3.4.10): <i>Falling objects are those that can be reasonably expected as a result of misbehavior, carrying tools, or similar activities. Open hoistway installations can also be subject to acts of vandalism (objects thrown from outside). Falling water is not addressed by this GESR.</i></p>		<p>3.4.10.1 GESR is self-explanatory.</p>
3.4.11	<p>3.4.11 LCU (Car) Ventilation Adequate ventilation shall be provided to the LCU (car).</p> <p>NOTE (3.4.11): <i>The intent of this GESR is to provide trapped passengers with sufficient air renewal. It is accepted that normal operation does not require particular measures due to the air exchange from door movement and the fact that journeys are relatively short.</i></p>	<p>2.14.2.3.3</p> <p>2.14.2.3.1</p>	<p>3.4.11.1 Forced ventilation on observation elevators ≥ 1 air change per minute (based on net inside car volume).</p> <p>3.4.11.2 Natural ventilation area $\geq 3.5\%$ inside car floor area (equally divided between top and bottom of car enclosure).</p>
3.4.12	<p>3.4.12 Fire/Smoke in LCU (Car) The interior of the LCU (car) shall be constructed of materials that are fire-resistant and that develop a low level of smoke.</p>		<p>3.4.12.1 See SPs related to GESR 3.1.13 for parameters related to materials for interior of LCU (car).</p>

Nonmandatory Table B-1 SPs for Each GESR*

SP #	Part 3 GESRs and related notes	References to A17.1/B44 requirement or other standards	SPs
	<p>NOTE (3.4.12): <i>The nature and quantity of the materials used in the LCU (car) (e.g., decorations) can be a serious source of harm during a fire. Factors that need to be considered include fire resistance, toxicity, etc., of materials. It is, however, understood that parts made of materials that do not strictly meet this specification may be used in small quantities inside the LCU (car) (e.g., control buttons and lighting diffusers).</i></p>		
3.4.13	<p>3.4.13 LCU (Car) in Flooded Areas Where there is a risk that the LCU (car) will descend into a flooded area, means shall be provided to detect and prevent descent into a flooded area.</p>		3.4.13.1 GESR is self-explanatory.
3.4.14	<p>3.4.14 Stopping Means Inside the LCU (Car) Means located inside the LCU (car) of intentionally interrupting the movement of the LCU (car) by the user shall be allowed only, if necessary, on elevators with a partially enclosed LCU (car) or elevators for special applications.</p> <p>NOTE (3.4.14): <i>An example of an elevator for special application is a freight elevator with truck-zone operation.</i></p>		3.4.14.1 GESR is self-explanatory.
3.4.15	<p>3.4.15 Landing Indication Means shall be provided to identify landings for the users in the LCU (car).</p> <p>NOTE (3.4.15): <i>Ignorance of one's location can create confusion and unpredictable reactions. In normal conditions, this is probably not a safety issue, but it can be significant in emergencies (firefighting, etc.).</i></p>		3.4.15 GESR is self-explanatory.



Nonmandatory Table B-1 SPs for Each GESR*

SP #	Part 3 GESRs and related notes	References to A17.1/B44 requirement or other standards	SPs
3.5	3.5 GESRs RELATED TO PERSONS IN WORKING AREAS		
3.5.1	<p>3.5.1 Working Space Adequate and safe working space shall be provided.</p> <p>NOTE (3.5.1): "Adequate" takes into account the ergonomic principles related to the tasks to be performed.</p>	<p>2.7.3.4.1(a)</p> <p>2.7.3.4.3(b)</p> <p>2.7.4.2(a)</p> <p>2.7.4.2(b)</p> <p>2.7.4.2(c)</p> <p>2.7.2.2.1</p> <p>2.7.2.2.2</p> <p>2.7.3.3.5</p>	<p>3.5.1.1 Access dimensions: (a) bodily entry required: ≥ 750 mm x 2030 mm; or (b) bodily entry not required: ≤ 600 mm x 600 mm.</p> <p>3.5.1.2 Minimum headroom: (a) machine and control room: 2130 mm; (b) spaces containing sheaves only: 1070 mm; and (c) other spaces: 1350 mm.</p> <p>3.5.1.3 Other clearances: (a) path for access ≥ 450 mm; (b) space for maintenance ≥ 450 mm; and (c) between floor levels without ladder ≤ 200 mm.</p>
3.5.2	<p>3.5.2 Accessible Equipment All elevator equipment requiring maintenance shall be safely accessible to elevator personnel.</p> <p>NOTE (3.5.2): If elevator elements requiring maintenance are not accessible, they can be neglected, which would render use of the installation unsafe. Elements of the elevator should be designed taking this into account. "Safely" indicates safe and easy access for maintenance operations.</p>	<p>ISO 11228-1</p> <p>ISO 13852.</p> <p>2.7.3.3.1</p> <p>OSHA OH&S</p>	<p>3.5.2.1 Maximum distance to reach and work on equipment: 820 mm.</p> <p>3.5.2.2 Use of a ladder: (a) For any access to work space at > 200 mm vertical distance, a ladder conforming to ANSI A14.3. (b) Comply with OSHA and OH&S Regulations.</p> <p>NOTE (3.5.2): See also parameters for GESR 3.5.1 and 3.5.3.</p>
3.5.3	<p>3.5.3 Access to and Egress from Working Spaces in the Hoistway Access to and egress from working spaces in or beyond the travel path shall be safe.</p> <p>NOTE (3.5.3): Egress from any working space should always be possible, regardless of the position of the LCU (car). Working spaces include the LCU (car) roof.</p>	<p>2.2.4.2</p> <p>2.2.4.4(c)</p> <p>2.12.7</p> <p>2.26.1.5</p>	<p>3.5.3.1 Maximum vertical distance to get to any working space, including access to car roof, without use of ladder or other means = 900 mm.</p> <p>3.5.3.2 Minimum access opening 750 mm wide x 1825 mm high.</p> <p>3.5.3.3 If PES devices are used for hoistway access operation: (a) enabling device to have SIL ≥ 3; (b) operating devices to have SIL ≥ 1; and (c) limit the car speed to 0.75 m/s.</p> <p>3.5.3.4 If PES devices are used to actuate car and/or hoistway door contact bypass, the devices to have a SIL ≥ 3.</p>

Nonmandatory Table B-1 SPs for Each GESR*

SP #	Part 3 GESRs and related notes	References to A17.1/B44 requirement or other standards	SPs
3.5.4	<p>3.5.4 Strength of Working Areas Means shall be provided to accommodate and support the weight of elevator personnel and associated equipment in any designated working area.</p> <p>NOTE (3.5.4): <i>The number of elevator personnel and the equipment that they carry or use to fulfill the anticipated working activities should be determined. Those activities do not include major repairs when the working area needs to be enlarged and reinforced.</i></p>	<p>2.1.3.3</p> <p>2.14.1.6</p> <p>2.7.5.3.2</p>	<p>3.5.4.1 Overhead floors: Minimum concentrated load 1000 N per 2000 mm².</p> <p>3.5.4.2 Car top: (a) 135 kg on 600 mm x 600 mm area: or (b) 45 kg at any point without permanent deformations.</p> <p>3.5.4.3 Working platform: Support 2000 N in any position with a load concentration of at least 1000 N over an area of 40000 mm², with a factor of safety ≥ 5.</p>
3.5.5	<p>3.5.5 Restrictions on Equipment in Elevator Spaces Only equipment related to the elevator installation or its protection shall be placed in the space containing the elevator equipment.</p> <p>NOTE (3.5.5): <i>The intent is to exclude non-elevator personnel (and personnel not acquainted with the dangers of elevator operation) from access to spaces needed for the location of the elevator equipment (the machine room, machine space, control room, control space, and hoistway) and to prevent the use of these spaces for storage.</i></p>		<p>3.5.5.1 GESR is self-explanatory.</p>
3.5.6	<p>3.5.6 Falling from Working Areas Means shall be provided to sufficiently mitigate the risk to elevator personnel of falling from any working area.</p> <p>NOTES (3.5.6): (1) <i>Working places in the hoistway, such as the LCU (car) roof, temporary platforms, etc., should be equipped with protective devices (e.g., a standard railing), if there is a risk of falling (e.g., a gap between the LCU (car) roof and the hoistway wall).</i> (2) <i>The means of prevention (e.g., a standard railing) should have sufficient height and strength.</i></p>	<p>2.14.1.7</p> <p>2.10.2</p> <p>2.1.3.6</p> <p>2.7.5.3.3</p>	<p>3.5.6.1 For horizontal gap > 300 mm, provide barrier ≥ 1070 mm high.</p> <p>3.5.6.2 If differences in floor levels > 400 mm, provide barrier ≥ 1070 mm high.</p> <p>3.5.6.3 Working platform: For horizontal gap > 300 mm and difference in level > 400 mm provide barrier ≥ 1070 mm high.</p> <p>NOTE (3.5.6): <i>See also 3.1.6 and 3.5.2.</i></p>



Nonmandatory Table B-1 SPs for Each GESR*

SP #	Part 3 GESRs and related notes	References to A17.1/B44 requirement or other standards	SPs
3.5.7	<p>3.5.7 LCU (Car) Movement under Control of Elevator Personnel Only elevator personnel shall be provided with means to prevent or to enable the movement of the LCU (car) when they are in the travel path. When elevator personnel are within reach of unprotected moving parts of the elevator, they shall be able to prevent or activate movement of the elevator equipment.</p> <p>NOTE (3.5.7): "Equipment" includes all possible moving parts, such as the LCU (car), counterweight, etc.</p>	<p>2.26.1.4.1 2.26.2.7 2.26.2.8 2.26.2.23 2.26.2.24 2.26.2.5 2.26.2.27 2.26.2.33 2.26.2.21</p>	<p>3.5.7.1 If PES device is used for following functions, the device to have SIL ≥ 3:</p> <ul style="list-style-type: none"> • actuation means for the transfer from any operation to inspection operation; • pit stop switch; • top of car stop switch; • remote machine room stop switch; • overhead machinery stop switch in hoistway; • freight in-car emergency stop switch; • remote counterweight hoistway stop switch; • firefighters' in-car stop switch; and • in-car stop switch.
3.5.8	<p>3.5.8 Uncontrolled, Unintended Equipment Movement Inside the Hoistway Means shall be provided to protect elevator personnel from the effects related to uncontrolled or unintended movement of equipment inside the hoistway. Any acceleration or deceleration to which elevator personnel are subjected as a result of uncontrolled or unintended movement shall be limited to sufficiently mitigate the risk of harm.</p> <p>NOTE (3.5.8): If the contact can be harmful, elevator personnel should be provided with means to mitigate such hazards, such as controls over equipment movement or permanently available screens that separate the moving parts from the working area so as to guard against accidental contact. "Equipment" includes all possible moving parts, such as the LCU (car), counterweight, etc.</p>		<p>3.5.8.1 Same as SP 3.4.6.</p>

Nonmandatory Table B-1 SPs for Each GESR*

SP #	Part 3 GESRs and related notes	References to A17.1/B44 requirement or other standards	SPs
3.5.9	<p>3.5.9 Means of Protection from Various Hazards Means shall be provided to adequately protect elevator personnel in working spaces from the effects of shearing, crushing, abrasion, laceration, high temperature, or entrapment.</p>	<p>2.3.2.2</p> <p>2.4.1.3</p> <p>ISO 13852</p> <p>EN 563</p> <p>2.7.5.3.4</p>	<p>3.5.9.1 Counterweight pit guard: (a) height (h) from pit floor $2100 \leq h \leq 2500$ mm; (b) strength and stiffness at least equivalent to 2 mm thick sheet steel; and (c) if perforated, reject a ball 25 mm in diameter</p> <p>3.5.9.2 Pit refuge space to be not less than (a) horizontal area 600 mm x 1200 mm and height 600 mm; or (b) horizontal area 450 mm x 900 mm and height 1070 mm.</p> <p>3.5.9.3 Refer to ISO 13852 Table 2 for guidance on reach and body space dimensions.</p> <p>3.5.9.4 Maximum surface temperature for elevator equipment to meet applicable requirements of EN 563.</p> <p>3.5.9.5 Working platforms: If car ≤ 300 mm from working platform: (a) shear protection ≥ 2130 mm height from platform; (b) strength and stiffness at least equivalent to 2 mm thick sheet steel; and (c) if perforated, reject a ball 25 mm in diameter</p> <p>NOTE (3.5.9): See also applicable parameters for GESRs 3.5.7 and 3.4.5.</p>
3.5.10	<p>3.5.10 Falling Objects in the Hoistway While in the hoistway, elevator personnel shall be adequately protected from falling objects.</p> <p>NOTE (3.5.10): Objects can fall because of an accidental reaction on the part of a person, e.g., handheld tools, loose material, etc.</p>		<p>3.5.10.1 GESR is self-explanatory.</p>
3.5.11	<p>3.5.11 Electric Shock in Working Spaces Equipment shall be designed and installed to minimize harm to elevator personnel due to the effects of electricity.</p> <p>NOTE (3.5.11): Elevator service sometimes requires that elevator personnel access live parts of electrical equipment. See also 3.1.9.</p>	2.26.4	<p>3.5.11.1 Meet requirements of: (a) NFPA 70 or CSA 22.1 as applicable; and (b) CSA B44.1/ASME A17.5 as applicable.</p>



Nonmandatory Table B-1 SPs for Each GESR*

SP #	Part 3 GESRs and related notes	References to A17.1/B44 requirement or other standards	SPs
3.5.12	3.5.12 Illumination of Working Spaces All working spaces and access thereto shall be provided with adequate illumination for the use of elevator personnel.	2.2.5.1 2.7.9.1	3.5.12.1 Minimum pit illumination ≥ 100 lx at floor level. 3.5.12.2 Minimum illumination in all machine rooms, control rooms, machinery spaces, and control spaces ≥ 200 lx at floor level.
<p>NOTE (3.5.12): Adequate illumination means that the level of light is sufficient for safe access and for performance of any maintenance operation of the elevator equipment. Illumination may be switched off in the absence of elevator personnel.</p>			

Nonmandatory Table B-2 Summary of Anthropometric Data

Item	Parameter	Dimension (mm)	Source
1	Standing height with arm in extension (over head finger tape reach)	2393	U.S. Army
2	Body reaching side to side (span tip to tip)	1960	U.S. Army
3	Grip reach (forward reach)	820	ISO 15534-3
4	Spaces allowing "free" movements Allowance for work clothing	100 20	ISO 15534-2
5	Foot width	113	ISO 15534-3
6	Foot length	285	ISO 15534-3
7	Foot thickness	96	ISO 15534-2
8	Shoe length	320	ISO 3411
9	Shoe width	115	ISO 3411
10	Arm length*	782	HUMANSCALE
11	Arm diameter	120	ISO 15534-3
12	Hand breadth (width)	97	ISO 15534-3
13	Hand depth (thickness)	30	ISO 15534-3
14	Hand length	205	ISO 3411
15	Finger thickness	23	ISO 15534-3
16	Finger diameter†	32	HUMANSCALE
17	Finger length	88	ISO 15534-2
18	Body height	1881	ISO 15534-3
19	Body shoulder width	495	HUMANSCALE
20	Body thickness	342	ISO 15534-3
21	Body weight (kg)	98.3	U.S. ARMY
22	Crouching dimensions height	1220	ISO 15534-2
23	Crouching dimensions depth	790	HUMANSCALE
24	Crouching dimensions width (shoulder)	495	HUMANSCALE
25	Head width	161	U.S. ARMY
26	Head length (to nose) (pronasale to back of head)	240	ISO15534-3
27	Head height (chin to top of head)	247	U.S. ARMY
28	Chest thickness	280	U.S. ARMY
—	Chest depth – Child	110	ANTHROKIDS
29	Chest width	367	U.S. ARMY
30	Step height	152-191	HUMANSCALE
31	Climbing height – distance between ladder rungs	min 180 max 300	HUMANSCALE
32	Step length (span)	284	HUMANSCALE

(Continued)



Nonmandatory Table B-2 Summary of Anthropometric Data

Item	Parameter	Dimension (mm)	Source
33	Hips width	378	HUMANSCALE
34	Elbow to Elbow (shoulder width)	545	ISO 15534-3
35	Minimum Gap to avoid crushing – Adult – Body	500	ISO 13854
36	Minimum Gap to avoid crushing – Adult – Head	300	ISO 13854
37	Minimum Gap to avoid crushing – Adult – Leg	180	ISO 13854
38	Minimum Gap to avoid crushing – Adult – Foot	120	ISO 13854
39	Minimum Gap to avoid crushing – Adult – Toes	50	ISO 13854
40	Minimum Gap to avoid crushing – Adult – Arm	120	ISO 13854
41	Minimum Gap to avoid crushing – Adult – Hand/Wrist/Fist	100	ISO 13854
42	Minimum Gap to avoid crushing – Adult – Finger	25	ISO 13854
43	Minimum Gap to avoid crushing – Child – Body	300	ANTHROKIDS
44	Minimum Gap to avoid crushing – Child – Head	200	ANTHROKIDS
45	Minimum Gap to avoid crushing – Child – Leg	110	ANTHROKIDS
46	Minimum Gap to avoid crushing – Child – Foot (Assume ½ Adult Dimension)	60	ANTHROKIDS
47	Minimum Gap to avoid crushing – Child – Toes	25	ANTHROKIDS
48	Minimum Gap to avoid crushing – Child – Arm	60	ANTHROKIDS
49	Minimum Gap to avoid crushing – Child – Hand/Wrist/Fist	70	ANTHROKIDS
50	Minimum Gap to avoid crushing – Child – Finger	12	ANTHROKIDS

* Value from the center of the body

† Value to give access

Unless stated as minimum, dimensions given in Nonmandatory Table B-2 will accommodate ninety-five percent of population (e.g., Item 6, foot length 285 mm, indicates that ninety-five percent of the population will have a foot length of 285 mm or less.)

Sources:

- (1) ISO 15534-2, Ergonomic design for the safety of machinery – Part 2: Principles for determining the dimensions required for access openings
- (2) ISO 15534-3, Ergonomic design for the safety of machinery – Part 3: Anthropometric data
- (3) ISO 3411 Earth Moving Machinery – Human Physical Dimensions of Operators and Minimum Operator Space Envelope
- (4) Humanscale Manual – Published by MIT Press
- (5) US Army – 1988 Anthropometric Survey of U.S. Army Personnel
- (6) ISO 13854, Safety of machinery. Minimum gaps to avoid crushing of parts of the human body (EN 349)
- (7) Anthrokids Web Site – <http://www.itl.nist.gov/iaui/ovrt/projects/anthrokids/> (95th percentile – M/F – 4.5 – 5.5 years old)

Other Sources of Anthropometric Data:

- (1) ISO 15534-1, Ergonomic design for the safety of machinery – Part 1: Principles for determining the dimensions required for openings for whole-body access into machinery
- (2) ISO 2860, Earth Moving Machinery – Minimum Access Dimensions
- (3) ISO 7250, Basic human body measurements for technological design
- (4) ISO 13852, Safety of machinery. Safety distances to prevent danger zones being reached by the upper limbs (EN 294)



NONMANDATORY APPENDIX C

RISK ASSESSMENT METHODOLOGIES

To verify conformance with the GESRs, it is necessary to perform a risk assessment of the elevator system, sub-system, component, or function to be utilized. This may be done using one of the methods developed for analyzing hazards and estimating risk.

This Code refers solely to the methodology described in ISO 14798 because it is the only document written specifically for use in the field of elevators, escalators, and moving walks and includes numerous elevator examples for use of the risk assessment process. To assist users of the ISO 14798 methodology, templates and other data are provided in Tables C-1, C-2.1, C-2.2, C-3.1, and C-3.2 in this Appendix.

However, in addition to the ISO 14798 methodology, there are other methods for risk assessment that could be used for verification of compliance with GESRs. They include, but are not limited to, the following:

- (a) ISO 14121, Safety of machinery – Principles of risk assessment, and also the following methods that are described in Annex B of ISO 14121:
 - (1) PHA;
 - (2) “What-if” method;
 - (3) FMEA;
 - (4) MOSAR;
 - (5) FTA;
 - (6) DELPHI technique;
- (b) US MIL STD-882 C, System safety program requirements, U.S. Department of Defense;
- (c) ZHA-Guide, Zurich hazard analysis: A brief introduction to the Zurich method of hazard analysis; and
- (d) IEC 61508-5, Functional safety of electrical/electronic/programmable electronic safety related systems – Part 5, Annex B.



Table C-1
Risk Assessment Template
 [for use in conjunction with ISO/TS 14798]

Purpose * and subject: _____ Moderator* _____ Date: _____

* Purpose, team moderator, and members could be recorded in a separate document

Case No.	Scenario			Risk elements estimate		Protective measures (risk reduction measure)	After protective measures		Residual risk
	Hazardous situation	Harmful event					S	P	
		Cause	Effect						
	Comments:								
	Comments:								
	Comments:								
	Comments:								
	Comments:								
S - Levels of severity of the harm (see Nonmandatory Table C-2.1):				P - Level of probability of occurrence of harm (see Nonmandatory Table C-2.2):					
1. high 2. medium 3. low 4. negligible				A: highly probable		B: probable		C: occasional	
				D: remote		E: improbable		F: highly improbable	

TABLES C-2.1 AND C-2.2 ESTIMATION OF RISK ELEMENTS, SEVERITY, AND PROBABILITY

C-2.1

The levels of severity are given in Table C-2.1 to provide approximate quantitative measures of the severity of effect (harm). It is recognized that the users of the ISO 14798 methodology may not be qualified to determine the actual harm in terms of injuries that a given individual may be suffering in a particular harmful event, but they may be able to quantify the estimated level of possible severity of effect (harm).

The descriptions of level of severity of harm (Table C-2.1) and probability levels (Table C-2.2) are given for guidance when risk assessment is performed in relation to elevators intended for general use and transportation. In special cases, such as the use of elevators by firefighters or by hospital personnel, the description of levels of severity and probability may need adjustments.

**Table C-2.1
Levels of Severity**

ID – Level of severity	Description
1 High	Death, system loss, or severe environmental damage
2 Medium	Severe injury, severe occupational illness, major system or environmental damage
3 Low	Minor injury, minor occupational illness, minor system or environmental damage
4 Negligible	Will not result in injury, occupational illness, system or environmental damage

C-2.2

The levels of probability are described in Table C-2.2 to give approximate quantitative measures of the probability of the occurrence of harm in a specific hazard scenario.

**Table C-2.2
Levels of Probabilities**

ID – Level of Probability	Description
A Highly Probable	Likely to occur frequently
B Probable	Likely to occur several times in the life cycle
C Occasional	Likely to occur at least once in the life cycle
D Remote	Unlikely but may possibly occur in the life cycle
E Improbable	Very unlikely to occur in the life cycle
F Highly Improbable	Probability cannot be distinguished from zero



**TABLES C-3.1 AND 3.2
 RISK ESTIMATION AND EVALUATION**

NOTE (Tables C-3): Tables C-3.1 and C-3.2 are mandatory if ISO 14798 methodology (see 2.7.1) is used.

**Table C-3.1
 Risk Estimation and Evaluation (see 2.7.4)**

Level of Probability	Level of Severity			
	1 High	2 Medium	3 Low	4 Negligible
A Highly probable	1A	2A	3A	4A
B Probable	1B	2B	3B	4B
C Occasional	1C	2C	3C	4C
D Remote	1D	2D	3D	4D
E Improbable	1E	2E	3E	4E
F Highly improbable	1F	2F	3F	4F

**Table C-3.2
 Risk Evaluation (see 2.7.4.2)**

Risk Group	Risk levels	Measure to be taken
I	1A, 1B, 1C, 1D, 2A, 2B, 2C, 3A, 3B	Protective measures required to reduce the risks
II	1E, 2D, 2E, 3C, 3D, 4A, 4B	Review is required to determine whether any further protective measure is appropriate, taking into account the practicability of the solution and societal values (see Note Table C-3.2)
III	1F, 2F, 3E, 3F, 4C, 4D, 4E, 4F	No action required

NOTE (Table C-3.2): Society may or may not tolerate a specific risk. Further measures may make use, service, etc., of the elevator impractical or impossible.

Table C-4 Guide for Team Moderator — Role, Skills, Duties, and Responsibilities

NOTE (Table C-4): This Guide is included for users of risk assessment methodology described in ISO 14798.

1. Role	Skilful moderation of the risk assessment team is very important for the results of a risk assessment. Poor team moderation can dramatically reduce the effectiveness of the risk assessment process.
2. Skills	The team moderator must have good knowledge and understanding of the methodology described in ISO 14798. In addition, the moderator should <ol style="list-style-type: none"> (a) have an overall understanding of the product or process being assessed, not necessarily having expertise in all aspects of the subject being analyzed; (b) have facilitating abilities, including good questioning skills; and (c) be able to assume an impartial view, free of any bias.
3. Duties and responsibilities	The following are the moderator's duties and responsibilities: <ol style="list-style-type: none"> (a) to form the team that is balanced in accordance with 2.7.2; (b) to ensure that the team members understand and accept rules of the risk assessment process; (c) to remain objective and to guide the team through a disciplined and focused assessment process; (d) to act as an unbiased facilitator rather than a participant in the debates of the team. When discussing topics and expressing opinions, the moderator may express his/her own opinion concerning the topic, but this shift from the moderator role should be an exception and clearly indicated to the team; (e) to stimulate in-depth discussion by the members, which is accomplished by using a thought-provoking process of questioning when developing the scenarios and reaching consensus; (f) to ensure that any scenario (see 2.7.3), including assumptions, if any, are clearly formulated and understood; (g) to ensure that the team work and decision-making process are properly documented (see 2.10.); and (h) to ensure that decisions are made in accordance with consensus principles.



NONMANDATORY APPENDIX D QUICK REFERENCES

Examples of Hazards (Table D-1);
Examples of Hazardous Situations (Table D-2);
Examples of Causes (Table D-3); and
Examples of Effects (Table D-4)

NOTE (Nonmandatory Appendix D): This Appendix does not constitute a comprehensive compilation of hazards, hazardous situations, causes, and effects. It is intended only as a guide.

Table D-1
Examples of Hazards

Type of hazards	Details and examples
1. Mechanical	
(a) Specific mechanical features	<ul style="list-style-type: none">• Mass and velocity (kinetic energy of elements in controlled or uncontrolled motion)• Acceleration, force• Inadequate mechanical strength• Potential energy or accumulated energy inside elastic elements (such as springs) or gases/liquids under pressure (such as hydraulic, pneumatic)
(b) Mechanical parts	<ul style="list-style-type: none">• Moving or rotating parts and relative movement of moving part – Shapes – sharp, pointed, rough, etc.
(c) Gravity mass and stability	<ul style="list-style-type: none">• Collapse of element supporting equipment or persons• Uneven or slippery area• Elevated unguarded area• Floor obstruction on walking/working area
2. Electrical	<ul style="list-style-type: none">• Live conductors• Live machine elements – from loss of insulation and/or protection• Electrostatic phenomena• Thermal effects
3. Radiation	<ul style="list-style-type: none">• Low frequency, radio frequency, microwave, X and gamma ray• Laser/infrared, visible and ultraviolet light
4. Chemical	<ul style="list-style-type: none">• Hazardous (harmful, toxic, corrosive)• Combustible or flammable
5. Neglecting ergonomic principles	<ul style="list-style-type: none">• Inadequate lighting• Inadequate visibility (poor layout of controls)• Difficult access to, or inadequate height of, work space



Table D-2
Examples of Hazardous Situations

Type of hazardous situation; presence of hazard to which persons can be exposed	Details and examples
1. Presence of mechanical hazards	
1.1 General mechanical	<p>Persons are in location or situation where it is possible for them</p> <ul style="list-style-type: none"> • to be exposed to energy sources: mass and velocity – kinetic energy of elements in controlled and uncontrolled motion. <p>EXAMPLE <i>Persons at the floor close to the unenclosed hoistway in which car and counterweight travel.</i></p> <ul style="list-style-type: none"> • to come in contact with a hazardous (sharp, pointed, etc.) shape • to be exposed to various hazards due to mechanical failure of a mechanical component • to approach sources of accumulated energy – in the form of elastic elements (springs) or gases/liquids under pressure (hydraulic, pneumatic)
1.2 Moving parts	Persons are in location where it is possible to come in contact with zones of entanglement, shearing, trapping, crushing/impact, friction/abrasion
1.3 Gravity	<p>Persons are in situation where they are or could be</p> <ul style="list-style-type: none"> • at height • near an elevated load or non-fixed component or tool • near an opening such as a car top, hole in the machine room floor, open well doors when car is away • on slippery, uneven, cluttered ground, floor, or area
2. Presence of electrical hazards	<p>Persons are in location or situation where there is a possibility for persons</p> <ul style="list-style-type: none"> • to contact live components (direct contact) • to access machines being electrified, e.g., following an insulation failure (indirect contact) • to approach parts under high voltage • to contact elements carrying electrostatic charges
3. Presence of thermal hazards	Persons are in location or situation where there is a possibility for a person's exposure to a hot or cold environment or surface, such as a user in the car or a worker in a cold or hot machine room, or a person touching a hot component
4. Presence of radiation hazards	Persons are in location or situation where they could be exposed to hazardous radiation source
5. Presence of chemical hazards	Persons are in location or situation where there is a source of ignition with flammable dusts, gases, or vapours generated by materials or products
6. Presence of hazards generated by neglecting ergonomic principles	<ul style="list-style-type: none"> • Elevator access area is inadequately lit – car interior is inadequately illuminated and visibility of controls is insufficient for users • Access to working area is through narrow and low openings



Table D-3
Examples of Causes (Component of Harmful Event)

Causes	Details and examples
1. Events involving general mechanical hazardous situations	
1.1 Breaking or failure of mechanical parts	<ul style="list-style-type: none"> • Any driving machine component, e.g. gear, shaft, drive sheave, brake, suspension means, hydraulic jack, valve, etc. • Car or hoistway entrance doors, their fixings, door mechanical lock, etc. • Car floor • Car or hoistway enclosures, enclosure lining, light fixtures, car or counterweight guiding means
1.2 Tipping, overturning, or falling of parts or tools	<ul style="list-style-type: none"> • Machine tipping or overturning • Falling tools used by mechanics
1.3 Breaking or failure of mechanical safety part	<p>The parts provided to stop the car safely should another elevator part fail, such as:</p> <ul style="list-style-type: none"> • car or counterweight safety or mechanical governor • emergency brake • buffer • door lock or interlock
2. Events involving moving parts, components	
2.1 Unexpected or unintended start of car movement	<p>Due to failure of a component, such as:</p> <ul style="list-style-type: none"> • a safety device (interlock or door contact) • safety-related circuit, • driving machine component (brake, shaft) • motion control system (failure of a relay, solid-state device, software, anomaly in logic)
	<p>EXAMPLE Car starts to move when landing door is open due to door interlock or its circuit failure, or due to the failure of the brake to hold car at the landing</p>
2.2 Car accelerated beyond its rated speed	<p>Due to failures of components, such as:</p> <ul style="list-style-type: none"> • motion control system • slowdown and stopping system (brake, shaft, gear)
2.3 Car accelerates or decelerates abruptly	<p>Due to failures of components, such as</p> <ul style="list-style-type: none"> • motion control system • brake
2.4 Unexpected start of elevator while a person is working in hoistway or machine room	<p>Due to various mechanical or control failure, mentioned in Table D1, Item 1</p>
3. Events involving or instigating gravity issues	<ul style="list-style-type: none"> • Slippery floor – possibility of a person tripping and falling on the floor • Hoistway door left open – possibility of a person falling into hoistway • Elevated working platform railing fails to hold worker, possibility of falling • Falling matter or material (e.g., a tool or elevator part)

Table D-4
Examples of Possible Effects

Effects of	Examples of effects		
1. Mechanical origin	<ul style="list-style-type: none"> • Abrasion • Being caught • Being dragged • Burning • Crushing 	<ul style="list-style-type: none"> • Cutting • Entanglement • Impact • Projection • Pulling out 	<ul style="list-style-type: none"> • Puncture • Severing • Shearing • Stabbing
2. Gravity	<ul style="list-style-type: none"> • Collapse • Crushing • Falling • Jamming 	<ul style="list-style-type: none"> • Lowering • Slipping • Slumping 	<ul style="list-style-type: none"> • Suffocation • Tripping • Wedging
3. Electrical causes	<ul style="list-style-type: none"> • Electric burns 	<ul style="list-style-type: none"> • Electric shock 	<ul style="list-style-type: none"> • Electrocutation
4. Thermal causes	<ul style="list-style-type: none"> • Heatstroke 	<ul style="list-style-type: none"> • Hypothermia 	<ul style="list-style-type: none"> • Suffocation
5. Chemical causes	<ul style="list-style-type: none"> • Burns – chemical or fire 	<ul style="list-style-type: none"> • Smoke or fumes – inhalation 	
6. Ergonomics	<ul style="list-style-type: none"> • Crushing, abrasion on undersize access 	<ul style="list-style-type: none"> • Claustrophobia 	<ul style="list-style-type: none"> • Skeletal and muscular dislocations



NONMANDATORY APPENDIX E EXAMPLE OF USE OF THIS CODE

E-1 INTRODUCTION

E-1.1

To demonstrate the use of the method for establishing safety described in this Code, an elevator-related example is presented in E-2. This example is intended for illustrative purposes only and is not an endorsement of solutions developed, probability and severity levels assessed, or any conclusions regarding mitigation or protective measures. The example merely demonstrates a process that would satisfy the procedural requirements of this Code.

E-1.2

The example demonstrates an approach in conforming to GESRs when a complete elevator system is fundamentally different from current elevator designs. In the example, alternative means for meeting the intent of specific design requirements specified in ASME A17.1/CSA B44 are illustrated.

E-1.3

In the example, the following process is illustrated:

- (a) determine the reason for, and subject of, the assessment;
- (b) propose an elevator system to be deployed;
- (c) identify GESRs that are applicable to the subject of analysis;
- (d) conduct risk assessment and mitigate identified risks; and
- (e) document the process.

E-2 EXAMPLE: PASSENGER ELEVATOR SYSTEM WITHOUT A CONVENTIONAL CAR, HOISTWAY, AND DOOR SYSTEM

E-2.1 Determine the Reasons for, and Subject of, this Risk Assessment

The reasons and subject are as follows:

- (a) verification that (safety) risks will be eliminated or sufficiently mitigated once the conceptual design of an elevator device (see E-2.3) for transportation of persons becomes an actual installation put into service; and
- (b) verification that the design of an elevator described in E-2.2, which apparently does not comply with most of the requirements specified in the ASME A17.1/CSA B44 Code, fully complies with GESRs.

E-2.2 Propose an Elevator System to be Deployed

NOTE (E-2.2): Fig. E-1 shows the initial concept of the elevator device. Figs. E-2 to E-4 show details of the elaborated elevator design resulting from the risk assessment in relation to the applicable GESRs.

E-2.2.1 Basic Requirements for the Proposed System

The conceptual design of the elevator system has the following specifications (see also Fig. E-1):

- (a) capacity – thirty persons;
- (b) speed – 0.5 to 1.0 m/s;
- (c) landings – 2 levels, the ground and gallery levels;
- (d) rise – 8 m;
- (e) location – public assembly building;
- (f) life cycle – 40 years;
- (g) driving machine – any type; and
- (h) automatic operation.



E-2.2.2 Additional Design Requirements

E-2.2.2.1

The building space is open from the ground level up to the ceiling, high above the gallery level. When people enter the building at the ground level and the elevator platform is located at the ground level, no elevator equipment above the platform obstructs the view of the whole space above the ground, up to the ceiling of the gallery level. No equipment is in view and no permanently installed hoistway enclosure is provided.

E-2.2.2.2

When the platform, occupied by users, is moving up towards the gallery landing, the users are able to view all space around them, including people on the ground and at gallery level.

E-2.3 Identification of GESRs that are Applicable to the Proposed System

Following the brief review of the design requirements for this elevator device, it became clear that the complete list of GESRs, as given in Part 3, should be used to ensure that each safety requirement that is applicable to this device is taken into consideration.

Consequently, all GESRs are listed in Nonmandatory Appendix Table E-2.3. The third column, by entry "YES", indicates that each GESR is to be taken into consideration. The fourth column is used to confirm, by entry "YES" or "NO", whether or not the specific GESR is indeed found applicable and that compliance with such a GESR has been demonstrated by risk assessment in Nonmandatory Appendix E-2.4. The entries "A17.1/B44" in the fourth column identify that conformity with the GESR is achieved by compliance with the noted ASME A17.1/CSA B44 requirement. Therefore no risk assessment is required in Nonmandatory Appendix Table E-2.4.

NOTE (E-2.3): When identifying applicable GESRs, the template in Nonmandatory Appendix A-4 could have been used. However, for the purpose of this example, Table E-2.3 has been abbreviated.

NOTE (E-2): It should be noted that the sequence of addressing the GESRs in this particular example differs from the order of GESRs in Table E-2.3. The main focus of this example is the platform upon which users stand, and which transports them vertically. The safety issues are best addressed by dealing with the GESRs relevant to the LCU (car) first, such as GESRs 3.4.1 to 3.4.15 in Category 3.4.

This is logically followed by 3.2 GESRs related to areas adjacent to the hoistway and 3.3 GESRs related to landing and LCU (car) entrances, etc.

Approaching the example in a different sequence would also lead to a similar outcome, provided that all the applicable GESRs are addressed and all identified risks are sufficiently mitigated.



Nonmandatory Table E-2.3 List of GESRs to be Verified for Conformance*

GESR #	Global Essential Safety Requirement	Compliance to be verified with this GESR?	RA Case # or A17.1/B44 requirement (from Table E-2.4)
3.1 COMMON GESRS RELATED TO PERSONS AT DIFFERENT LOCATIONS			
3.1.1	Supports for Elevator Equipment The means used to support the elevator equipment shall be capable of sustaining all loads and forces (including impact forces) imposed during normal and emergency operations.	YES	YES Case 22
3.1.2	Elevator Maintenance Where maintenance is required to ensure continued safety, appropriate instructions shall be provided, and elevator personnel shall perform any required work.	YES	YES Case 23
3.1.3	Equipment Inaccessible to Users and Non-Users Equipment that is hazardous shall not be directly accessible to users and non-users.	YES	YES Case 24
3.1.4	Floors of the LCU (Car) and Working Areas The floors of the LCU (car) and standing areas of workplaces shall minimize the risk of tripping and slipping.	YES	YES Case 25
3.1.5	Hazards Due to Relative Movement Users and non-users shall be protected from the effects of shearing, crushing or abrasion, or other injuries due to: (a) relative movement of the LCU (car) to external objects; and (b) relative movement of the elevator equipment NOTE (3.1.5): For elevator personnel, see 3.5.9.	YES	YES Case 26
3.1.6	Locking Landing Doors and Closing LCU (Car) Doors Any movement of the LCU (car) that is hazardous to persons shall be stopped if any hoistway door is open or unlocked or the LCU (car) door is not closed.	YES	A17.1/B44 3.12
3.1.7	Evacuation Means and procedures shall be provided to enable trapped users or elevator personnel to be safely released and evacuated.	YES	A17.1/B44 8.6.10.4
3.1.8	Sharp Edges Means shall be provided to sufficiently mitigate the risk of users and non-users being exposed to sharp edges. NOTE (3.1.8): For elevator personnel, see 3.5.	YES	YES Case 27
3.1.9	Hazards Arising from the Risk of Electrical Shock Where electricity is provided, means shall be provided to sufficiently mitigate the risk to users and non-users of exposure to electrical shock and related hazards. NOTE (3.1.9): For elevator personnel, see 3.5.11.	YES	A17.1/B44 3.26.1(d)

* Table E-2.3 is not to be construed as a complete representation of the entire process required by this Code.



Nonmandatory Table E-2.3 List of GESRs to be Verified for Conformance*

GESR #	Global Essential Safety Requirement	Compliance to be verified with this GESR?	RA Case # or A17.1/B44 requirement (From Table E-2.4)
3.1.10	Electromagnetic Compatibility The safe operation of an elevator shall not be influenced by electromagnetic interferences.	YES	A17.1/B44 3.26.1(d)
3.1.11	Illumination of LCU (Car) and Landings The LCU (car) and landings shall be provided with adequate illumination during use.	YES	YES Case 28
3.1.12	Effects of Earthquake In areas subject to earthquake, means shall be provided to minimize the risk to users of the LCU (car) and elevator personnel of the foreseeable effects of earthquakes on the elevator equipment. <i>COMMENT (3.1.12): Elevator not in seismic zone.</i>	YES	NO
3.1.13	Hazardous Materials The characteristics and quantity of material used for the manufacture and construction of the elevator shall not lead to hazardous situations.	YES	YES Case 29
3.1.14	Environmental Influences Users and elevator personnel shall be protected from environmental influences. <i>COMMENT (3.1.14): Elevator is located within building.</i>	YES	NO
3.2 GESRs RELATED TO PERSONS ADJACENT TO THE ELEVATOR — FALLING INTO HOISTWAY			
3.2	Means shall be provided to prevent the risk of users, non-users, and elevator personnel falling into the hoistway	YES	YES Case 7
3.3 GESRs RELATED TO PERSONS AT THE ELEVATOR ENTRANCE			
3.3.1	Access and Egress Safe means of access and egress shall be provided to the LCU (car) at landings.	YES	YES Case 8
3.3.2	Horizontal Sill-to-Sill Gap The horizontal gap between the sill of the LCU (car) and that of the landings shall be limited.	YES	YES Case 9
3.3.3	Alignment of LCU (Car) and Landing When users enter or exit the LCU (car), its platform and landing shall be substantially aligned.	YES	YES Case 10
3.3.4	Self-Evacuation from an LCU (Car) Self-evacuation of users shall be possible only when the LCU (car) is at or near a landing.	YES	YES Case 11
3.3.5	Gap between the Landing Doors and LCU (car) Doors The space between the landing doors and LCU (car) doors shall not allow the presence of users.	YES	YES Case 12



Nonmandatory Table E-2.3 List of GESRs to be Verified for Conformance*

GESR #	Global Essential Safety Requirement	Compliance to be verified with this GESR?	RA Case # or A17.1/B44 requirement (From Table E-2.4)
3.3.6	Means to Reopen Doors when LCU (Car) is at Landing Means shall be provided to reopen the LCU (car) and landing doors if their closing is obstructed when the LCU (car) is at the landing.	YES	YES Case 13
3.4 GESRs RELATED TO PERSONS IN THE LCU (CAR)			
3.4.1	Strength and Size The LCU (car) shall accommodate and support the rated load and a reasonably foreseeable overload.	YES	YES Cases 1 and 1.1
3.4.2	LCU (Car) Support/Suspension Means shall be provided to support the fully loaded LCU (car) and a reasonably foreseeable overload.	YES	YES Case 2
3.4.3	Overloaded LCU (Car) Means shall be provided to prevent an overloaded LCU (car) from attempting to leave a landing.	YES	YES Case 3
3.4.4	Falling from an LCU (Car) Means shall be provided to prevent users from falling from the LCU (car).	YES	YES Case 1.2
3.4.5	LCU (car) Travel Path Limits The vertical travel of the LCU (car) shall be limited to prevent the LCU (car) from uncontrolled running beyond the travel path.	YES	A17.1/B44 – 3.18, 3.22.1, 3.25, 3.26.4
3.4.6	Uncontrolled, Unintended Movement of an LCU (Car) Means shall be provided to limit uncontrolled or unintended movement of the LCU (car).	YES	A17.1/B44 – 3.18
3.4.7	LCU (Car) Collision with Objects in or beyond Travel Path Means shall be provided to avoid collision of the LCU (car) with any equipment in the travel path that could cause injuries to users.	YES	YES Case 4
3.4.8	LCU (Car) Horizontal and Rotational Motion Horizontal or rotational motion of the LCU (car) shall be limited to sufficiently mitigate the risk of injury to users and elevator personnel.	YES	YES Case 5
3.4.9	Change of Speed or Acceleration Means shall be provided to ensure that any change of speed or acceleration of LCU (car) shall be limited to minimize the risk of injury to the users.	YES	A17.1/B44 – 3.18, 3.25, 3.26
3.4.10	Objects Falling on the LCU (Car) LCU (car) users shall be protected from falling objects. <i>COMMENT (3.4.10): The elevator is located in an enclosed building.</i>	YES	YES Case 1.2.2
3.4.11	LCU (Car) Ventilation Adequate ventilation shall be provided to the LCU (car). <i>COMMENT (3.4.11): Elevator is not fully enclosed.</i>	YES	YES
3.4.12	Fire/Smoke in LCU (Car) The interior of the LCU (car) shall be constructed of materials that are fire-resistant and that develop a low level of smoke.	YES	YES Case 6

Nonmandatory Table E-2.3 List of GESRs to be Verified for Conformance*

GESR #	Global Essential Safety Requirement	Compliance to be verified with this GESR?	RA Case # or A17.1/B44 requirement (From Table E-2.4)
3.4.13	<p>LCU (Car) in Flooded Areas Where there is a risk that the LCU (car) will descend into a flooded area, means shall be provided to detect and prevent descent into a flooded area. <i>COMMENT (3.4.13): Elevator not located in flood plain.</i></p>	YES	NO
3.4.14	<p>Stopping Means Inside the LCU (Car) Means located inside the LCU (car) of intentionally interrupting the movement of the LCU (car) by the user shall be allowed only, if necessary, on elevators with a partially enclosed LCU (car) or elevators for special applications. <i>COMMENT (3.4.14): Elevator partially enclosed and operated only by designated attendant.</i></p>	YES	YES
3.4.15	<p>Landing Indication Means shall be provided to identify landings for the users in the LCU (car). <i>COMMENT (3.4.15): Elevator serves only two landings, visible from the LCU (car).</i></p>	YES	YES
3.5 GESRs RELATED TO PERSONS IN WORKING AREAS			
3.5.1	<p>Working Space Adequate and safe working space shall be provided.</p>	YES	YES Case 14
3.5.2	<p>Accessible Equipment All elevator equipment requiring maintenance shall be safely accessible to elevator personnel.</p>	YES	YES Cases 15 and 15.1
3.5.3	<p>Access to and Egress from Working Spaces in the Hoistway Access to and egress from working spaces in or beyond the travel path shall be safe.</p>	YES	YES Case 16
3.5.4	<p>Strength of Working Areas Means shall be provided to accommodate and support the weight of elevator personnel and associated equipment in any designated working area.</p>	YES	YES Case 17
3.5.5	<p>Restrictions on Equipment in Elevator Spaces Only equipment related to the elevator installation or its protection shall be placed in the space containing the elevator equipment.</p>	YES	A17.1/B44 3.7 and 3.8
3.5.6	<p>Falling from Working Areas Means shall be provided to sufficiently mitigate the risk to elevator personnel of falling from any working area.</p>	YES	YES Case 18
3.5.7	<p>LCU (car) Movement under Control of Elevator Personnel Only elevator personnel shall be provided with means to prevent or to enable the movement of the LCU (car) when they are in the travel path. When elevator personnel are within reach of unprotected moving parts of the elevator, they shall be able to prevent or activate movement of the elevator equipment.</p>	YES	YES Case 19



Nonmandatory Table E-2.3 List of GESRs to be Verified for Conformance*

GESR #	Global Essential Safety Requirement	Compliance to be verified with this GESR?	RA Case # or A17.1/B44 requirement (From Table E-2.4)
3.5.8	Uncontrolled, Unintended Equipment Movement Inside the Hoistway Means shall be provided to protect elevator personnel from the effects related to uncontrolled or unintended movement of equipment inside the hoistway. Any acceleration or deceleration to which elevator personnel are subjected as a result of uncontrolled or unintended movement shall be limited to sufficiently mitigate the risk of harm.	YES	A17.1/B44 3.18
3.5.9	Means of Protection from Various Hazards Means shall be provided to adequately protect elevator personnel in working spaces from the effects of shearing, crushing, abrasion, laceration, high temperature, or entrapment	YES	YES Case 20
3.5.10	Falling Objects in Hoistway While in the hoistway, elevator personnel shall be adequately protected from falling objects.	YES	YES Case 1.2.2
3.5.11	Electric Shock in Working Spaces Equipment shall be designed and installed to minimize harm to elevator personnel due to effects of electricity.	YES	A17.1/B44 3.26.1(d)
3.5.12	Illumination of Working Spaces All working spaces and access thereto shall be provided with adequate illumination for the use of elevator personnel.	YES	YES Case 21

E-2.4 Risk Assessment and Risk Mitigation

NOTE (E-2.4): In this example, the risk assessment methodology of ISO 14798 was used. The following are summarized steps taken from ISO 14798.

E-2.4.1 Step 4: Identification of Scenarios: Hazardous Situations and Harmful Events (or Causes and Effects)

The template in Nonmandatory Appendix Table C-1 is used to record the scenarios. Since the concept of this elevator cannot meet most of the requirements established in the current codes, scenarios were formulated to verify compliance of the design with each GESR.

The first column in the table gives the "Case number" of the scenario being analyzed. The second column was inserted in Nonmandatory Appendix Table E-2.4 and E-2.5 to give the references to the GESRs being analyzed. The next three columns give descriptions of the scenario.

E-2.4.2 Step 5: Risk Estimation

Risk elements that are the severity of possible effects or harm (S) and probability of occurrence of that harm (P) have been estimated using guidelines set out in Part 2 and Nonmandatory Appendix C of this Code and Section 5.5 of ISO 14798. The results of the estimation are given in two columns labelled "S" and "P" following the scenario columns.

E-2.4.3 Step 6: Risk Evaluation

By inserting the levels of severity and probability in Nonmandatory Appendix Table C-3.1, the levels of risk are estimated. Using Nonmandatory Appendix Table C-3.2, the level of risk is evaluated.

E-2.4.4 Step 7: Has the Risk been Sufficiently Mitigated?

When the risk falls in Risk Group I or II (see Nonmandatory Appendix Table C-3.2), further protective measures or actions are taken if necessary. In the case of a risk identified as Risk Group III, no further action is required.

E-2.4.5 Protective Measures

In response to the team's assessment as a result of the risk scenarios, the designers propose protective measures that would reduce the identified risk, as recorded in the Protective Measures column in the table.

NOTE (E-2.4.5): Figures E-2 to E-4 illustrate several protective measures taken to mitigate the risks and to achieve compliance with GESRs.

E-2.4.6 Repeating Steps 5, 6, and 7

When proposed protective measures are in place, step 5 is repeated and the same scenario is reviewed again. The severity and probability are estimated again and recorded in the table, in two columns following the Protective Measures column. Steps 6 and 7 are repeated to verify that the risk has been sufficiently mitigated and to determine whether any residual risk requires further mitigation. Residual risk is recorded in the last column of the table.

E-2.5 Documentation of the Risk Assessment and Mitigation Process

The process is documented in Nonmandatory Appendix Table E-2.4.

E-2.6 Explanation of the Development of the Proposed Design Using the Process of Risk Assessment in Table E-2.4

The equipment design envisaged to meet the performance criteria in E-2.2.1 and E-2.2.2 was a hydraulic elevator with unspecified guidance (driven by a hydraulic jack) with a platform of unspecified size or strength and without walls. The elevator would have automatic operation.

In assessing the elevator, the Risk Assessment team started with GESRs related to persons on the platform. Case 1 applies to GESR 3.4.1. The hazardous situation is a result of persons on the platform and the elevator moving towards an upper landing. The harmful event is caused by the fact that the platform is not designed for the load and therefore collapses. The effect is that the persons fall from the platform. Due to the height of the fall, the level of severity is judged to be high (i.e., Level 1, Table C-2.1). Since the strength of the platform is unspecified, it is assumed to be incapable of carrying any load and will collapse as soon as any load is applied. The level of probability from Table C-2.2 would therefore be highly probable (i.e., Level A). Table C-3.1 shows the risk level to be 1A. Table C-3.2 indicates that the risk is Risk Group I and that protective measures are to be taken to reduce the risks.

In applying protective measures, the process described in 2.8.1 is followed. Requirement 2.8.1 states that protective measures shall be applied in a specific order. Requirement 2.8.1(a) states: "Eliminate the hazard, where possible, by revisions to the design." In this case, eliminating the hazard would require preventing people from being on the platform, which effectively defeats the function of the elevator and is therefore not possible. Requirement 2.8.1(b) states that "if the identified hazard cannot be eliminated in accordance with 2.8.1(a), further measures shall be taken to reduce the risk. These measures include (1) re-designing the equipment to increase the reliability ...".

By designing the platform to meet SP 3.4.1.3 and SP 3.4.1.4 in Table B-1, the platform cannot collapse. This effectively addresses the cause of the harmful event.

Since the hazard has not been eliminated, the severity level still remains level 1, but the probability of this occurring is reduced to level F (Table C-2.2). A residual risk still remains, i.e., users can still fall from the edge of the platform. This risk is addressed in Case 1.1.



A similar process is followed in each case throughout the exercise. In every instance the hierarchy of implementing protective measures, i.e., first eliminate the hazard by design where possible, etc., is followed. Thus, the elevator evolves by design from an open platform of undefined strength to a fully closed elevator car with a ceiling, in response to the mitigation of identified risks.

It should be recognized that other solutions are possible and that this example is by no means the only safe configuration. However, the example illustrates the process of following the methodology in this Code, but it is not intended to be an exhaustive study of this particular design.



**Nonmandatory Table E-2.4
Risk Assessment per Nonmandatory Appendix C
[Modified by inserting "GESR Ref." Column]***

Case #	GESR Ref.	Scenario			Risk elements estimate		Protective measures (risk reduction measures)	After protective measures		Residual risk
		Hazardous situation	Harmful event		S	P		S	P	
			Cause	Effect						
3.4 Essential safety requirements related to persons in LCU (car)										
1	3.4.1	Persons are on the platform of LCU (car). Elevator moving towards the upper landing.	Platform not designed for the load, collapses.	Users fall from collapsing platform.	1	A	Design the LCU (car) platform to meet SP 3.4.1.3 and SP 3.4.1.4 in Nonmandatory Appendix Table B-1.	1	F	Users can still fall from platform edges.
Comments: (1) No further action required with respect to falling risk due to collapse of platform, as strength of platform has been addressed and the risk sufficiently mitigated. (2) Other strength-related issues will be resolved by other GESRs. (3) Falling hazards due to insufficient platform area and the lack of protection around the platform edges are addressed in Cases #1.1 and 1.2.										
1.1	3.4.1	30 or more persons are on the platform of LCU (car). Elevator moving towards the upper landing.	Platform not large enough to accommodate the persons.	Users fall off platform edges.	1	B	Design the LCU (car) platform to meet SP 3.4.1.1 in Nonmandatory Appendix Table B-1.	1	C	Persons can still fall off. See mitigation under Case #1.2.
1.2	3.4.4	30 or more persons are on the platform of LCU (car). Elevator moving towards the upper landing.	Unlimited space exists around edge of platform. Users step over edge.	Users fall off platform edges.	1	C	Provide a 1070 mm (consistent with 2.10.2.1 in A17.1/B44) solid barrier around the perimeter of the platform and an LCU (car) entrance gate made of framed glass. The strength will comply with SP 3.4.4 in Nonmandatory Appendix Table B-1. The LCU (car) gate will be mechanically locked and will be unlocked automatically only after the LCU (car) is stopped at the landing.	1	D	Users can climb over 1070 mm high barrier and fall, particularly if elevator stalls between landings.

* The example in Table E-2.4 reflects process and is not to be construed as a complete risk assessment of the entire process required by this Code.

(Continued)



**Nonmandatory Table E-2.4
 Risk Assessment per Nonmandatory Appendix C
 [Modified by inserting "GESR Ref." Column]***

Case #	GESR Ref.	Scenario		Risk elements estimate		Protective measures (risk reduction measures)	After protective measures		Residual risk	
		Hazardous situation	Harmful event Cause	Effect	S		P	S		P
		Comments: (1) Climbing over barriers in a moving elevator is foreseeable misuse, as people are used to enclosed elevators. (2) If an elevator is stalled, people may attempt to self-evacuate by climbing over the barrier.								
1.2.1	3.4.4	30 or more persons are on the platform of LCU (car). Elevator moving towards the upper landing. Barrier installed in compliance with safety parameter SP 3.4.4 in Nonmandatory Appendix B-1, Item 2.21.	Elevator stalls in between landings. Users climb over 1070 mm high barrier.	Users fall off platform barrier.	1	D	Install transparent barrier with strength in compliance with SP 3.4.4 and SP 3.3.1.7 in Nonmandatory Appendix B-1, and height of 2400 mm, which is in excess of Nonmandatory Appendix B-2, Item 1.	1	E	Users can still climb out over ~ 2400 mm high barrier if assisted by other users.
		Comment: This is one solution to mitigate the residual hazard. Other solutions may also be available.								
1.2.2	3.4.4	30 or more persons are on the platform of LCU (car). Elevator moving towards the upper landing. Barriers installed in compliance with SP 3.4.4 in Nonmandatory Appendix Table B-1 and Nonmandatory Appendix B-2, Item 18.	Elevator stalls in between landings. Users assist other users to climb over ~ 2400 mm high barrier.	User falls from barrier into space around the platform.	1	E	Provide a transparent ceiling in compliance with SP 3.5.4.2 in Nonmandatory Appendix B-1.	4	F	
		Comments: (1) The fall hazard has been effectively eliminated by enclosing the platform. Thus, the severity is reduced to 4 and the probability to F. (2) By making the enclosure transparent, the design requirement E-2.2.2.2 is met. (3) The implementation of SP 3.5.4.2 in Nonmandatory Appendix B-1 also addresses GESR 3.4.10 [objects falling on LCU (car)].								

(Continued)

Nonmandatory Table E-2.4
Risk Assessment per Nonmandatory Appendix C
[Modified by inserting "GESR Ref." Column]*

Case #	GESR Ref.	Scenario			Risk elements estimate		Protective measures (risk reduction measures)	After protective measures		Residual risk
		Hazardous situation	Harmful event		S	P		S	P	
			Cause	Effect						
2	3.4.2	Persons are on the platform of LCU (car). Elevator moving towards the upper landing.	No or insufficient means of LCU (car) support are provided.		1	A	The LCU (car), users, and 25% overload will be supported by a hydraulic jack sized in accordance with all applicable parts of SP 3.4.2.3 in Nonmandatory Appendix B-1. Means complying with GESR 3.4.3 will be provided.	1	F	No action required.
3	3.4.3									
Comments: (1) Verification of the means of conformance with 3.4.3 will be provided in accompanying documentation. (2) Strength-related issues stated in Case #1 have been addressed in this case.										
4	3.4.7	Users are in LCU (car) when it impacts objects (a) in its travel path (bridge); or (b) at or beyond travel terminals.	1 Insufficient distance between LCU (car) and objects in its path of travel. 2 Inappropriate guidance of LCU (car), due to design or failure. 3 Bridge deploys in path.	Users impact LCU (car) enclosure or are thrown out of LCU (car).	1	C	The hydraulic plunger will be internally guided so that no sway or rotational movement will be possible. System provided to prevent bridge from deploying while LCU (car) is in motion. Horizontal clearances and detection means will be provided meeting SP 3.4.7 in Nonmandatory Appendix B-1.	4	E	No action required.
Comment: Documentation would be provided to explain deployment of bridge and plunger guidance system.										

(Continued)



**Nonmandatory Table E-2.4
Risk Assessment per Nonmandatory Appendix C
[Modified by inserting "GESR Ref." Column]***

Case #	GESR Ref.	Scenario		Risk elements estimate		Protective measures (risk reduction measures)	After protective measures		Residual risk	
		Hazardous situation	Harmful event Cause	Effect	S		P	S		P
5	3.4.8	Users are on the platform. The LCU (car) motion is not smooth. It moves along a curved path having horizontal or rotational components.	LCU (car) movement is not properly guided with rigid rails.	LCU (car) loses stability. It collides with structural or other objects around its path. Users lose balance and fall or bump into each other.	1	C	See mitigation for GESR 3.4.7.	4	E	No action required.
<p>Comments: (1) Severity reduced because hazard eliminated. (2) The probability is reduced because a minor failure of LCU (car) guiding system can still occur.</p>										
6	3.4.12	LCU (car) is not designed to resist fire.	Fire occurs in LCU (car).	User exposed to fire, toxic fumes, and smoke.	2	E	LCU interior is fitted with materials complying with SP 3.4.12 in Nonmandatory Appendix B-1.	3	F	No action required.

(Continued)





Nonmandatory Table E-2.4
Risk Assessment per Nonmandatory Appendix C
[Modified by inserting "GESR Ref." Column]*

Case #	GESR Ref.	Scenario			Risk elements estimate		Protective measures (risk reduction measures)	After protective measures		Residual risk
		Hazardous situation	Harmful event		S	P		S	P	
			Cause	Effect						
3.2 Essential safety requirements related to persons adjacent to the elevator										
7	3.2.1	Persons are at floor area around the LCU (car) travel path or entrance area to the elevator. Open space between the floor and the LCU (car) travel path.	Persons lean into travel path.	Persons lose balance and fall into the travel path.	1	A	To mitigate risk of persons falling from the gallery level into the LCU (car) travel path, top landing will be provided with a framed-glass locked gate 1100 mm in height that is automatically unlocked only when the LCU (car) is stopped level with the landing. The strength of the gate meets SP 3.2.1 in Nonmandatory Appendix B-1. Falling from the bottom landing will not be possible because, regardless of the position of the LCU (car), there will be no open gap between the bottom landing floor and under the LCU (car) structure more than 10 mm.	1	E	No action required.
Comment: See also GESR 3.1.5.										

(Continued)

**Nonmandatory Table E-2.4
 Risk Assessment per Nonmandatory Appendix C
 [Modified by inserting "GESR Ref." Column]***

Case #	GESR Ref.	Scenario			Risk elements estimate		Protective measures (risk reduction measures)	After protective measures		Residual risk
		Hazardous situation	Harmful event		S	P		S	P	
			Cause	Effect						
3.3 Essential safety requirements related to persons at the entrance to LCU (car)										
8	3.3.1	Users enter or exit LCU (car).	(1) Narrow opening.	(1) Stuck in narrow opening.	3		(1) Gate openings 1000 mm.	3	F	No action required.
8	3.3.1		(2) Door not open fully. (3) Door closes too soon or too fast.	(2) Injury caused while forcing door open. (3) Impacted by door.	3	B	(2) LCU (car) and each landing is provided with double, centre-opening, power-operated swing gates, controlled by an attendant from the LCU (car), who initiates door opening and closing by a constant-pressure control button, so as to mitigate risks in (2) and (3). (3) Gates can open only when the LCU (car) is stopped level with landing sill, when outer portion of the landing and LCU (car) gates swing towards each other and interlock to create guarding 1100 mm in height along the sides of the bridge between the LCU (car) and landing sills (see Fig. E-4). Gate designed to open towards car. (4) Glass in the LCU and landing doors conforms to SP 3.3.1.7 in Nonmandatory Appendix B-1.	3	F	No action required.
					2	B		1	A	Users can fall from the bridge.

(Continued)



**Nonmandatory Table E-2.4
Risk Assessment per Nonmandatory Appendix C
[Modified by inserting "GESR Ref." Column]***

Case #	GESR Ref.	Scenario			Risk elements estimate		Protective measures (risk reduction measures)	After protective measures		Residual risk
		Hazardous situation	Harmful event		S	P		S	P	
			Cause	Effect						
9	3.3.2	Users enter or exit LCU (car).	(1) User falls off side of bridge.	(1) and (2) User falls in travel path space.	1	A	(1) Bridge guarded on both sides with 1070 mm (consistent with 2.10.2.1 in A17.1/B44) high solid barrier.	1	F	No action required.
9	3.3.2		(2) Users falls through the gap between the LCU (car) and landing sill. (3) User's shoe enters the gap.	(3) User trips and falls onto landing.	3	B	(2) The sill-to-sill gap before the landing and LCU (car) gates open will be 1000 mm. However, before the gates can open, a bridge between the LCU (car) and landing will be automatically formed. (3) Once the gates open, there will be no gaps > 10 mm.	3	E	No action required.
		Comment: See also GESR 3.3.1 and 3.3.5.								
10	3.3.3	Users enter or exit LCU (car).	LCU (car) is not level with landing floor because door opens before LCU (car) is level.	User on foot or in a wheelchair trips, falls.	2	B	LCU (car) aligned before the gate opens (see also Fig. E-3).	2	F	No action required.
		Comment: See also GESR 3.3.1.								

(Continued)

Copyright © 2007 by the American Society of Mechanical Engineers. No reproduction may be made of this material without written consent of ASME.



**Nonmandatory Table E-2.4
 Risk Assessment per Nonmandatory Appendix C
 [Modified by inserting “GESR Ref.” Column]***

Case #	GESR Ref.	Scenario			Risk elements estimate		Protective measures (risk reduction measures)	After protective measures		Residual risk
		Hazardous situation	Harmful event		S	P		S	P	
			Cause	Effect						
11	3.3.4	User is trapped in the LCU (car), which is not at a safe vertical distance from a landing. Rescue help is not arriving.	The user attempts self-rescue by opening LCU (car) door, or gate and landing door which is 1000 mm below LCU (car) level, or tries to squeeze between the LCU (car) and hoistway enclosure.	Users fall down to landing, or inside hoistway, or are crushed if LCU (car) moves.	1	C	An attendant will be present at the LCU (car) to take action.	1	E	No action required.
12	3.3.5	Distance between the landing and LCU (car), as well as the door-to-door distance, is large and user enters the space.	A user when entering or exiting LCU (car) enters space between landing and LCU (car) gates.	User is entrapped between landing and LCU (car) doors and crushed by moving LCU (car) or falls into hoistway.	1	B	Once gate is opened there is no space in which to become trapped.	4	E	No action required.

Comment:
 (1) See GESR 3.3.1 and 3.3.2 and Fig. E-4.
 (2) Severity level 4 because there is no risk of falling and suffering high degree of harm.

(Continued)



**Nonmandatory Table E-2.4
Risk Assessment per Nonmandatory Appendix C
[Modified by inserting "GESR Ref." Column]***

Case #	GESR Ref.	Scenario			Risk elements estimate		Protective measures (risk reduction measures)	After protective measures		Residual risk
		Hazardous situation	Harmful event		S	P		S	P	
			Cause	Effect						
13	3.3.6	LCU (car) and landing gates close while users are in the doorway.	(1) Gate impacts the user or the user is entrapped between the gate panels or panels and frame, because reopening devices are not provided or failed. (2) User contacts gate panel surfaces while the panels are moving.	(1) User body parts are sheared, crushed. (2) The user's hand is abraded when drawn into gap between door panel and frame.	2	A	Gates to meet SP 3.3.1 in Nonmandatory Appendix B-1. Gate is controlled by an attendant.	3	E	No action required.
3.5 Essential safety requirements related to persons in working areas										
14	3.5.1	Elevator personnel are in working spaces, be it in the machinery space outside hoistway, inside the hoistway, in the hoistway overhead or pit, or on the LCU (car) top, to perform maintenance or repairs on various elevator parts.	The working space is inadequate. Not enough area to stand on or move. Small clearances between the elevator personnel and moving/rotating parts. Not able to reach equipment without use of ladders.	Personnel trip, fall, get entangled, crushed.	2	B	Meet SP 3.5.1 in Nonmandatory Appendix B-1. No maintenance or anticipated repairs are to be performed from underneath the platform.	4	E	No action required.
Comment: Severity level 4 because, being a working space, possibility of very low degree of severity always exists.										
15	3.5.2	Elevator personnel stand on ladder in working space in reach of items requiring maintenance.	Elevator personnel attempt to reach the items requiring maintenance.	Personnel fall.	2	C	Design equipment such that a reach of ≤ 820 mm is required from working space level.	4	E	No action required.
Comment: Placing equipment within reach. A ladder is not required.										

(Continued)



**Nonmandatory Table E-2.4
Risk Assessment per Nonmandatory Appendix C
[Modified by inserting "GESR Ref." Column]***

Case #	GESR Ref.	Scenario			Risk elements estimate		Protective measures (risk reduction measures)	After protective measures		Residual risk
		Hazardous situation	Harmful event Cause	Effect	S	P		S	P	
15.1	3.5.2	Elevator personnel stand in working space; other equipment is located between elevator personnel and equipment requiring maintenance.	Elevator personnel attempt to reach the items requiring maintenance.	Personnel exposed to intervening equipment.	2	C	Meet SP 3.5.1 in Nonmandatory Appendix B-1.	4	E	No action required.
16	3.5.3	Elevator personnel attempt to access equipment requiring maintenance.	Elevator personnel jump into the pit or onto the LCU (car) top.	Personnel fall, trip, are crushed or entrapped.	1	B	Access to and egress from working spaces complies with SP 3.5.3 in Nonmandatory Appendix B-1.	4	E	No action required.
Comment: Severity level 4 because, being a working space, possibility of very low degree of severity always exists.										
17	3.5.4	Two or three persons together with heavy tools and equipment enter the working area to perform repair.	Floor of the area collapses under the total load.	Personnel exposed to falling, crushing, and impact.	2	C	Provide working space capable of carrying anticipated load.	4	F	No action required.
Comment: Severity level 4 because, being a working space, possibility of very low degree of severity always exists.										
18	3.5.6	Equipment requires maintenance from an elevated platform by elevator personnel.	Space exists around the perimeter of the platform.	Personnel fall from the platform.	1	D	No elevated working areas to be provided.	4	F	No action required.
19	3.5.7	Elevator personnel are in a working area, inside the hoistway, or in machinery area. Specific work requires the elevator to run and stop while the work is performed.	LCU (car) starts uncontrolled movement.	Personnel are exposed to shearing, falling, crushing, and impact.	2	C	Implement constant pressure operation from car only. Control devices and associated circuitry meet applicable requirements of EPDs in SP 3.5.7 in Nonmandatory Appendix B-1.	2	F	No action required.

(Continued)



**Nonmandatory Table E-2.4
Risk Assessment per Nonmandatory Appendix C
[Modified by inserting "GESR Ref." Column]***

Case #	GESR Ref.	Scenario			Risk elements estimate		Protective measures (risk reduction measures)	After protective measures		Residual risk
		Hazardous situation	Harmful event Cause	Effect	S	P		S	P	
20	3.5.9	Elevator personnel are subjected to various hazards in a working area, inside the hoistway, or in machinery area.	Elevator personnel contact equipment.	Personnel are exposed to shearing, crushing, abrasion, entrapment, or high temperatures.	2	D	Design work space to eliminate exposure.	4	F	No action required.
21	3.5.12	Elevator personnel are in a working area.	Illumination is low.	The job is not properly done, endangering safety of users or elevator personnel.	2	C	Provide illumination levels conforming to SP 3.5.12 in Nonmandatory Appendix B-1.	2	F	No action required.
3.1 Common essential safety requirements related to persons in different locations and in relation to different sub-systems										
22	3.1.1	Persons in or around elevator equipment which has supports to which they are attached.	During normal or emergency operation supports fail, which affects stability and operational readiness of critical components, including LCU (car).	The person is exposed to shearing, falling, crushing, and impact.	2	C	Provide supports for all elevator equipment in compliance with applicable SPs in 3.1.1 in Nonmandatory Appendix B-1.	2	F	No action required.

(Continued)



**Nonmandatory Table E-2.4
Risk Assessment per Nonmandatory Appendix C
[Modified by inserting "GESR Ref." Column]***

Case #	GESR Ref.	Scenario		Risk elements estimate		Protective measures (risk reduction measures)	After protective measures		Residual risk	
		Hazardous situation	Harmful event Cause	Effect	S		P	S		P
23	3.1.2	Persons working in or around elevator.	The users assigned to do the work have not received adequate training or instruction related to the elevator installation on which they are assigned to work, with respect to (a) personal safety procedures; and (b) equipment and functions that are critical for the safety of users and non-users.	The person is exposed to shearing, falling, crushing, and impact. Users are exposed to various safety hazards – crushing, falling, shearing.	1	D	Documentation for this elevator will include maintenance manual outlining requirements for knowledge and experience as well as specific instructions, procedures, and training needed for maintaining elevator.	1	F	No action required.
24	3.1.3	Non-elevator personnel gain access to elevator machinery and equipment.	Persons come in contact with moving or rotating equipment or unprotected electrical equipment.	The person is exposed to shearing, falling, crushing, electrical shock, and impact.	1	C	Provide protection in conformance with applicable SPs in 3.1.3 in Nonmandatory Appendix B-1.	1	F	No action required.
25	3.1.4	(1) Users are in LCU (car) with slippery or uneven surface.	(1) User trips or slips.	(1) User falls.	3	C	Design equipment in conformance with applicable SPs in 3.1.4 in Nonmandatory Appendix B-1.	3	E	No action required

(continued)

Copyright © 2007 by the American Society of Mechanical Engineers. No reproduction may be made of this material without written consent of ASME.



Nonmandatory Table E-2.4 (Concluded)
Risk Assessment per Nonmandatory Appendix C
[Modified by inserting "GESR Ref." Column]*

Case #	GESR Ref.	Scenario			Risk elements estimate		Protective measures (risk reduction measures)	After protective measures		Residual risk
		Hazardous situation	Harmful event Cause	Effect	S	P		S	P	
		(2) Elevator personnel are in working area; working area surfaces are slippery or not level.	(2) Elevator personnel trip or slip.	(2) Elevator personnel fall.	1	D		1	F	
26	3.1.5	(1) Users on LCU (car) extend or protrude body parts out of LCU (car). (2) Persons at floors around the LCU (car) path extend or protrude body part towards the LCU (car) or other elevator equipment inside the path.	(1) LCU (car) has insufficient protection on sides allowing users to contact moving equipment. (2) Insufficient protection between surrounding floors or elevator equipment too close to the floor perimeters.	Body parts are sheared, crushed, impacted.	2	B	Design equipment in conformance with applicable SPs in 3.1.5 in Nonmandatory Appendix B-1.	2	F	No action required.
27	3.1.8	Persons are around elevator equipment with sharp edges.	Persons contact sharp edges.	Persons get hurt.	3	C	Design equipment in conformance with applicable SPs in 3.1.8 in Nonmandatory Appendix B-1 and remove sharp edges in design.	4	F	No action required.
28	3.1.11	Persons are in or around elevator.	Illumination is low.	Persons trip, fall, are impacted.	3	C	Provide illumination conforming with applicable SPs in 3.1.11 in Nonmandatory Appendix B-1.	3	F	No action required.
29	3.1.13	LCU (car) designed with hazardous material: (1) User in LCU (car). (2) Persons in vicinity of elevator installation.	Users are exposed to smoke or toxic materials, due to materials not being fire-resistant.	Persons are exposed to smoke and toxicity.	3	C	(1) LCU (car) fire resistance will meet applicable SPs in 3.1.13 in Nonmandatory Appendix B-1.	3	F	No action required.
					3	D	(2) Building materials conform to building code requirements.	3	F	



Figure E-1 Determination of the Subject of the Assessment

Complete elevator system:

- (a) capacity – thirty persons;
- (b) speed – 0.5 to 1.0 m/s;
- (c) landings – 2 levels, the ground and gallery levels;
- (d) rise – 8 m;
- (e) location – public assembly building;
- (f) life cycle – 40 years;
- (g) driving machine – any type; and
- (h) automatic operation.

Preliminary design concept

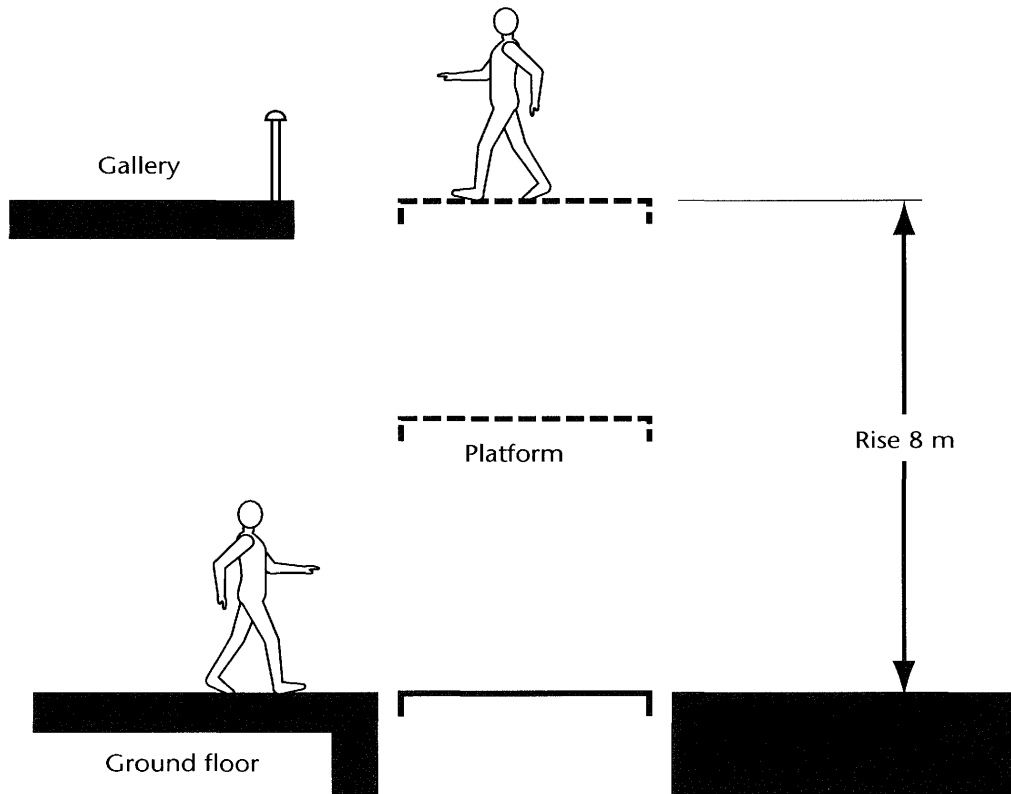
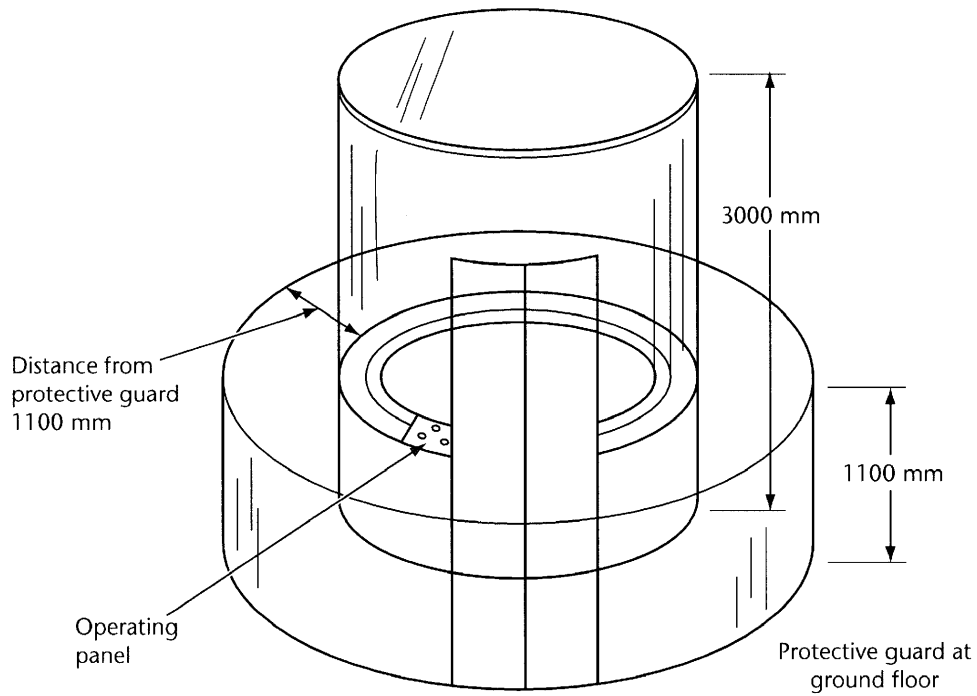

Figure E-2a
Elaboration of the Design Concept



Protective guard at ground floor and LCU

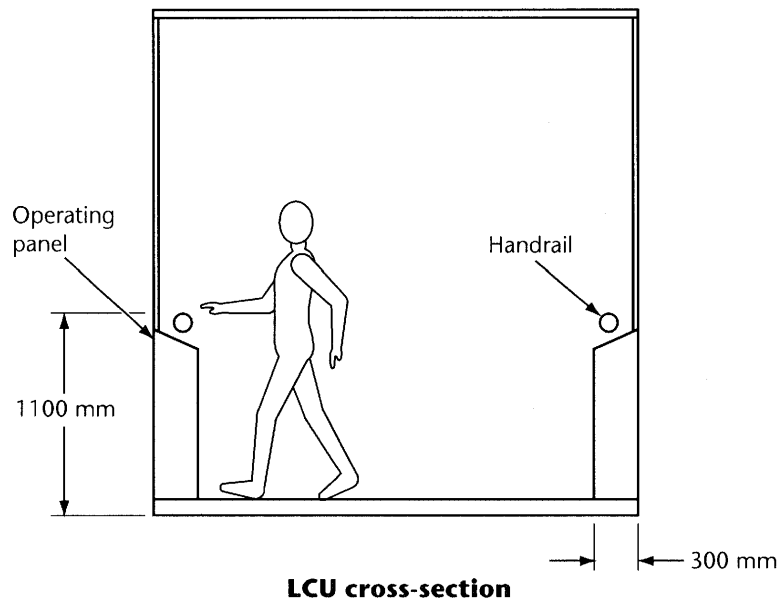

Figure E-2b
View of Ground Guard and Raised LCU

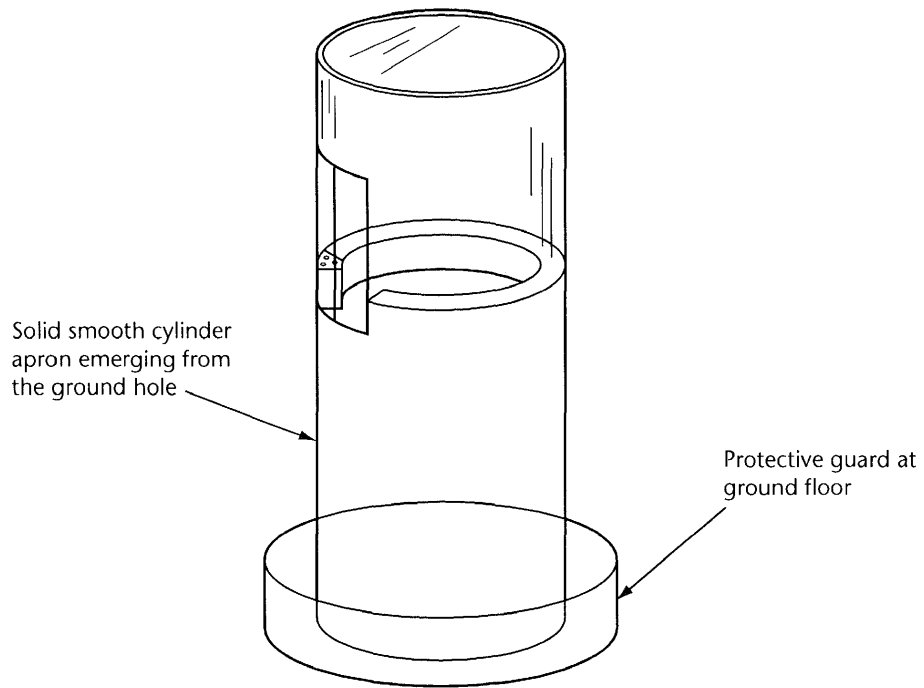
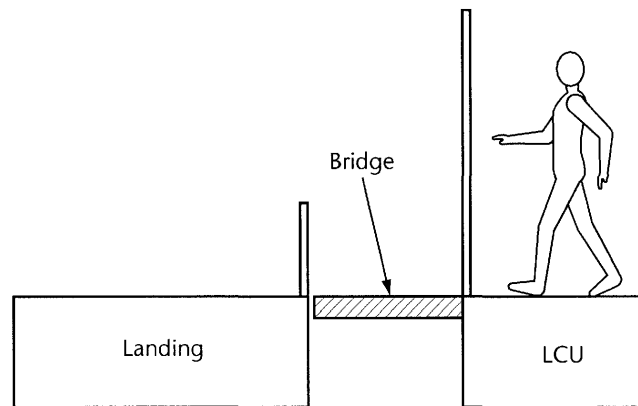
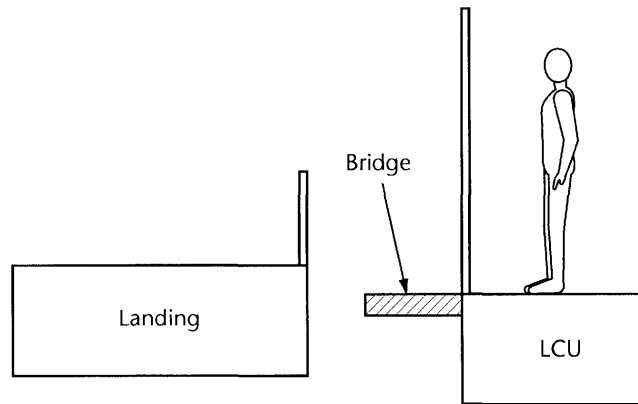
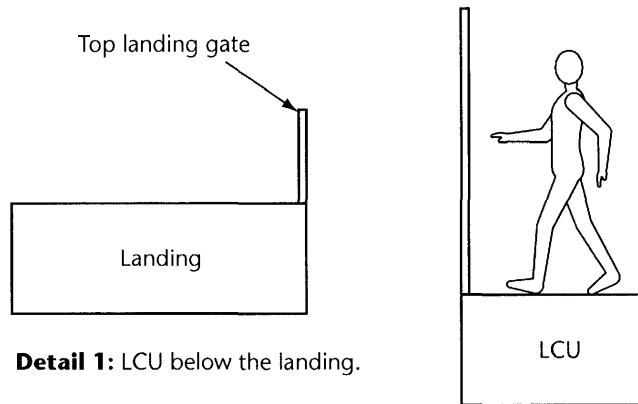
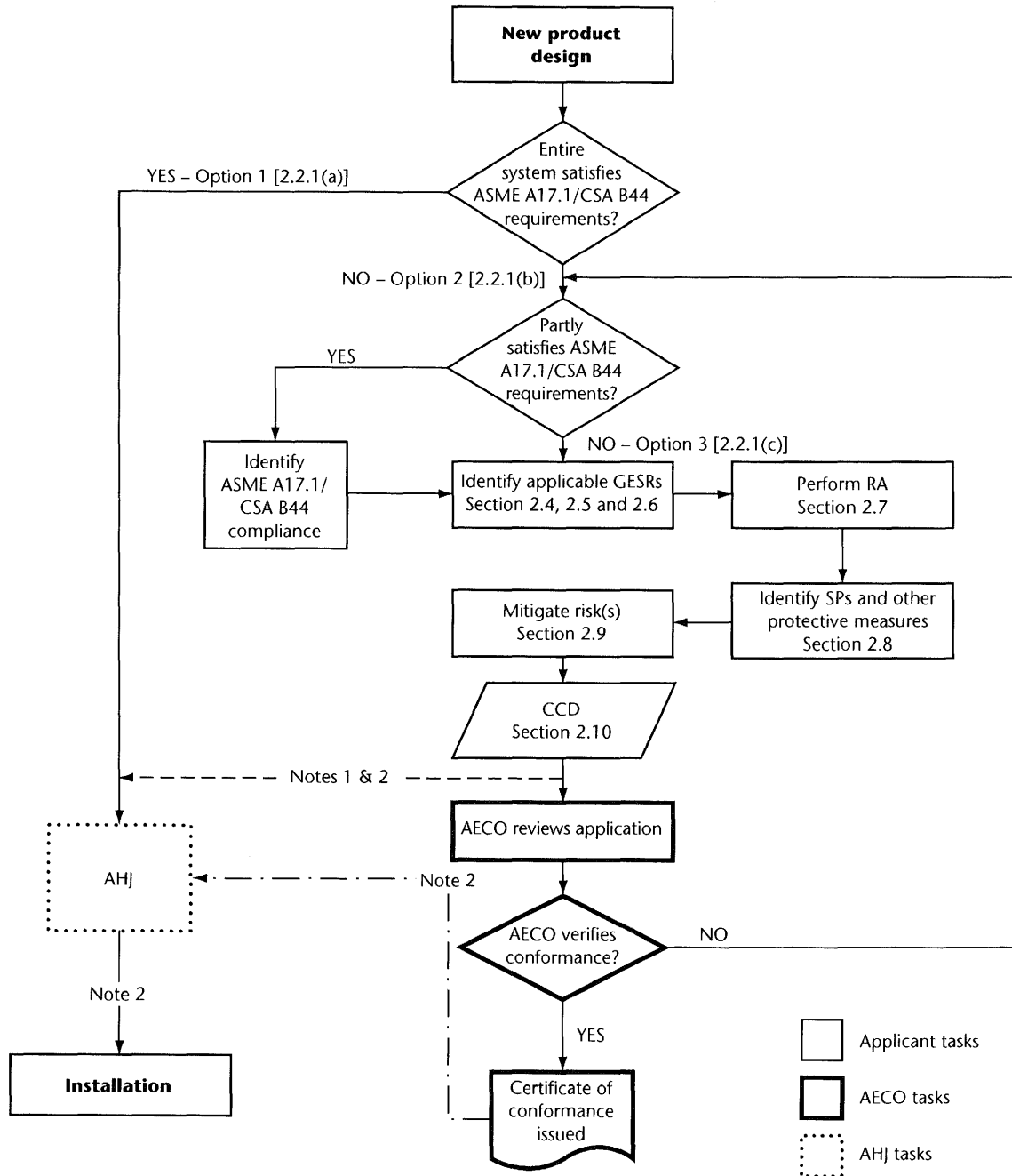

Figure E-3
Elaboration of Design Concept LCU – Landing Bridge



NONMANDATORY APPENDIX F ASME A17.7/CSA B44.7 Process

Figure F-1



NOTES

- (1) Recognition that AHJ may directly evaluate CCD.
- (2) Regulatory process outside scope of this Code

Figure E-4 Elaboration of the Design Concept

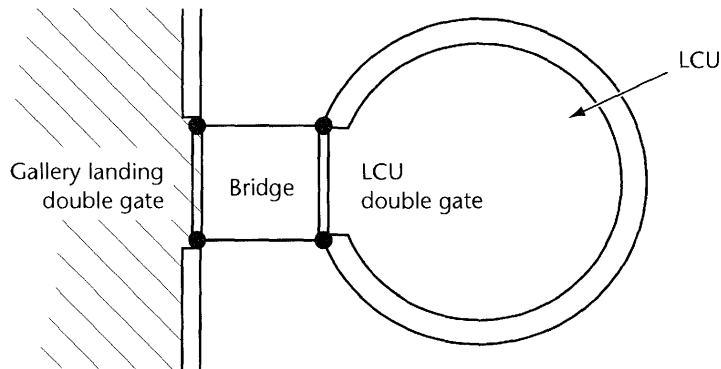

Sequence 0: Status — LCU stopped at gallery landing with bridge extended in place.

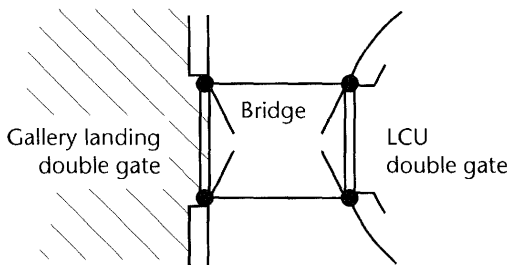

Sequence 1: outer gates start to open to form the bridge side guard.

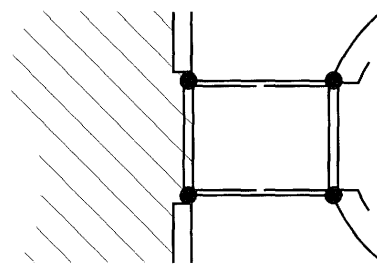

Sequence 2: outer gates fully open — the bridge guard is formed.

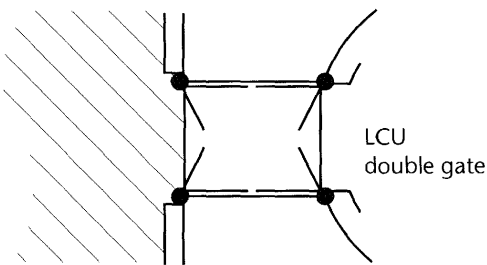

Sequence 3: inner gates start to open.

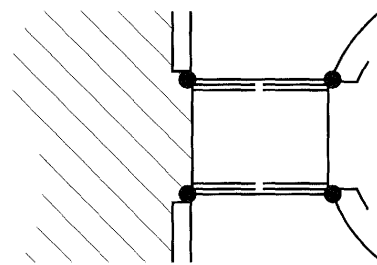

Sequence 4: inner gates fully open, locked in place. Users enter and exit LCU under supervision of attendant.